

Ventilated façade

1 General

These application instructions are specifically intended for the fastening of CEDRAL as outside wall cladding on a ventilated and insulated structure. A number of basic principles are given that must be adhered to. For variations or additional advice one can always contact EURO PANELS OVERSEAS N.V..

This application instruction for CEDRAL can be used in combination with the application instruction for OPERAL SOFFIT and the application instructions for TRIMS.

2 Cladding material

The following EURO PANELS OVERSEAS N.V. products are treated in this document.

- | | | |
|----------|---|-------|
| • CEDRAL | : | 10 mm |
|----------|---|-------|

For product data and the details of the processing of CEDRAL reference is made to the CEDRAL product information sheet, available from EURO PANELS OVERSEAS N.V..

Remarks concerning the wood colours “CL 1xx RC”:

- Cut edges have to be treated with the hydrophobation product ETERSILAN
- Applications with visible fixings (e.g. vertical or flat horizontal installation) are not advised.

3 Area of application

These instructions apply for buildings up to a certain height and subjected to a maximum actual wind load in a certain wind zone. The maximum intermediate distance of the supporting structure is determined in relation to the occurring wind load taking into account a safety factor. The table below only shows non-binding reference values for the wind loads. The exact values can be found in the standards NBN B 03-002-1; NEN 6702:2001 and NBN-EN 1991-1-4.

The fixing of CEDRAL sidings to a building height higher than 20m is not treated in this application guideline. For installation on building height over 20m high, special measures and calculations need to be considered.

Location	Building height	Middle area façade		Edge area façade and single span	
		Max. actual wind load	Max. center-to-center distance supporting laths	Max. actual wind load	Max. center-to-center distance supporting laths
Wind zone	m	N/m ²	mm	N/m ²	mm
Land	0-10	650	600	1000	500
Land	10-20	800	600	1200	500
Coast	0-20	1000	500	1500	400

The width of the edge area amounts to at least 1 m from the corner of the building and must be further determined on the basis of prevailing national standards and conditions. If variations of the aforementioned load limits occur (e.g. due to certain location or form factors, etc.), the design must be determined by building services engineers.

When the façade panels are exposed to weather conditions (rain, sun) they may only be assembled on a vertical or leaned over supporting structure. For ceiling applications reference is made to the relevant application guidelines.

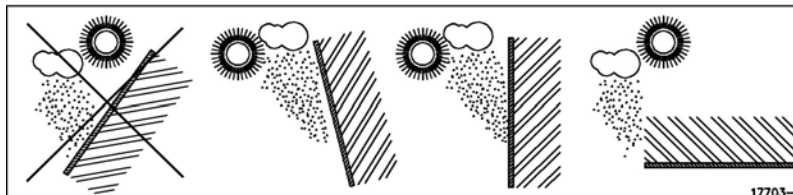

4 Supporting structure

The supporting laths are fixed at a certain distance (depending on the required insulation thickness and air cavity) on the back construction.

The supporting structure must be able to resist the wind forces exerted on the building and the load of its own weight.

- maximum buckle under the influence of strain : $\leq \text{span}/300$
- safety factor calculation of strength : 3

The quality of the wood must suffice with regard to that described in the prevailing standards for this area of application. The wood must also be protected against being affected by fungi, etc. in accordance with the prevailing standard.

- minimum characteristic bending strength of wood : 18 N/mm²
- minimum average modulus of elasticity : 9000 N/mm²

The fastening of CEDRAL must always take place with a ventilated cavity. The necessary openings are provided on the bottom side, top side and in the details to allow sufficient ventilation.

- ventilation openings above/below : $\geq 10 \text{ mm/m}$ or $100 \text{ cm}^2/\text{m}$

Building height	0-10 m	10-20 m
Minimum cavity width	20 mm	25 mm

Mineral wool with a water-repellent black protective coating is recommended for insulation. The insulation is fixed with synthetic insulation fastenings. The insulation is fastened according to the instructions of the producer of the insulation, e.g. with five insulation fasteners per square meter.

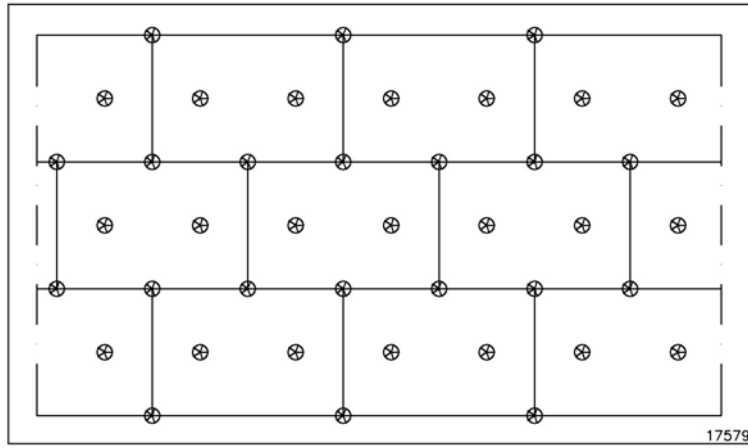

If the wooden supporting laths are fixed with brackets, the insulation is fastened after the fitting of the brackets and before the fitting of the wooden supporting laths. A slit is cut in the insulation at the bracket.

It is preferable to isolate the bracket from the supporting wall by using a piece of hard insulation material (THERMOSTOP).

If the wooden supporting laths are fixed with wooden cross laths, the insulation is placed in between the cross laths before the fitting of the wooden supporting laths.

VARIANT 1: INSULATION BETWEEN ADJUSTABLE BRACKETS

With uneven back constructions the vertical wooden supporting laths can be fixed using adjustable brackets.

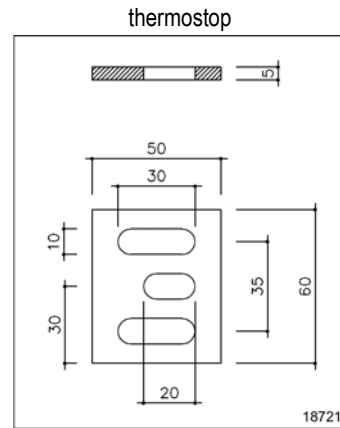
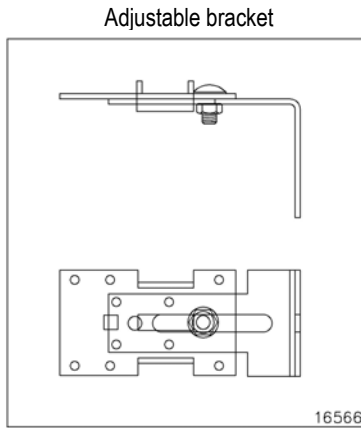
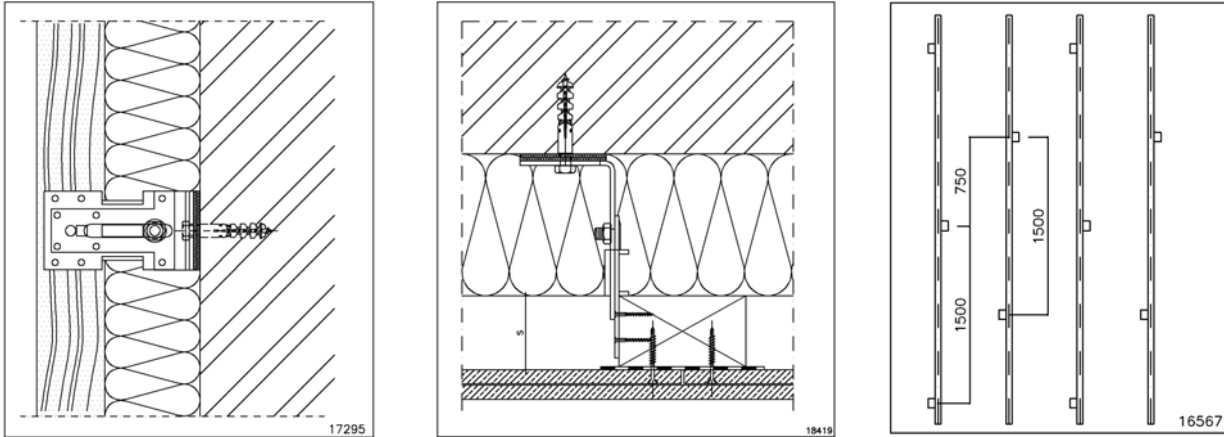

The supporting lath is sufficiently thick to enable the good fix of the brackets, and the adjustable bracket has the following properties.

- minimum thickness supporting lath : 50 mm
- bracket material : at least Sendzimir galvanised steel
- continuous remote control : 60 - 120 mm (back construction - rear lath)

The fixing of the adjustable brackets to the back construction is individually determined for each project depending on the nature and the state of the wall to be claded.

In general a minimum pull-out value per fixing point of 3 kN (300kg) is recommended. This must however be verified for each project. For concrete and solid brick a stainless steel wood screw (min. 7 mm diameter) with a hexagonal head and associated nylon plug is used. The screws with hexagonal head are, however, not tightened too firmly so thread in the nylon plug is not damaged.

For other surfaces (hollow brick, cellular concrete, system walls, etc.) suitable fastening means must be used to be able to accommodate the tractive force occurring as a result of the wind load and the shearing forces as a result of the own weight. If necessary a pull-test must be conducted on site. The supporting laths are to be fixed to the adjustable bracket by means of four stainless steel wood screws per bracket. The screws must penetrate at least 25 mm in the supporting lath.

To obtain a stable supporting structure, the adjustable brackets are alternately placed to the left and the right of the supporting lath. The brackets of two supporting laths located next to each other are also fitted staggered.

VARIANT 2: INSULATION BETWEEN HORIZONTAL CROSS LATHS

For wooden frame constructions or sufficiently smooth back constructions, the insulation is placed between horizontal wooden cross laths to which the vertical supporting laths are fixed.

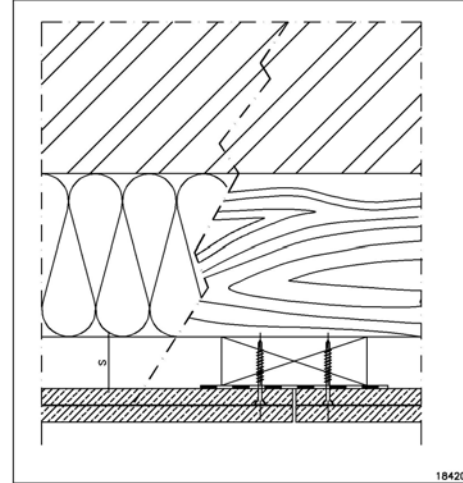
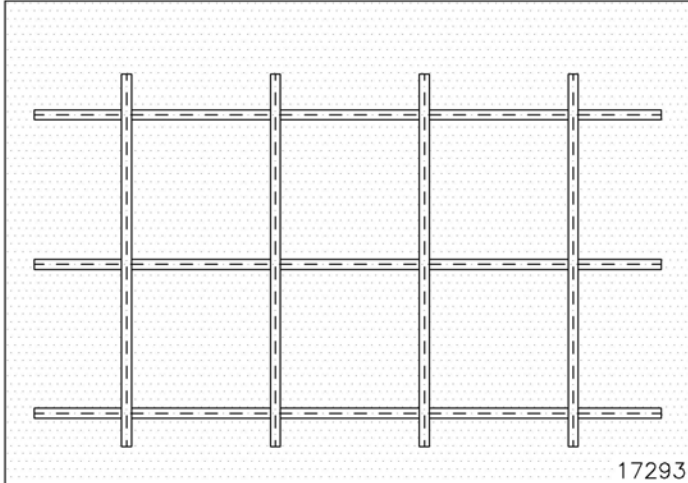

The fixing of the horizontal cross laths to the back construction is individually determined for each project depending on the nature and the state of the wall to be claded.

In general a minimum pull-out value per fixing point of 3 kN (300kg) is recommended. This must however be verified for each project. For concrete and solid brick a stainless steel wood screw (min. 7 mm diameter) with a countersunk head and nylon plug is usually used. The screws are, however, not tightened too firmly so thread in the nylon plug is not damaged.

For other surfaces (hollow brick, cellular concrete, system walls, etc.) suitable fastening means must be used to be able to accommodate the tractive force occurring as a result of the wind load and the shearing forces as a result of the own weight. If necessary a pull-test must be conducted on site.

The vertical supporting laths are fixed to the horizontal wooden cross laths by one or two stainless steel wood screws per crossing point.

- minimum width of horizontal cross lath : 50 mm
- minimum thickness of horizontal cross lath : 30 mm

2 fastening accessories per crossing point

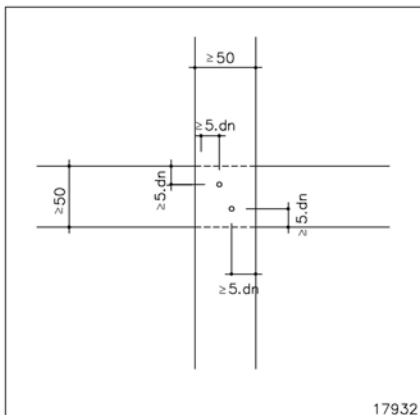

1 fastening accessory per crossing point

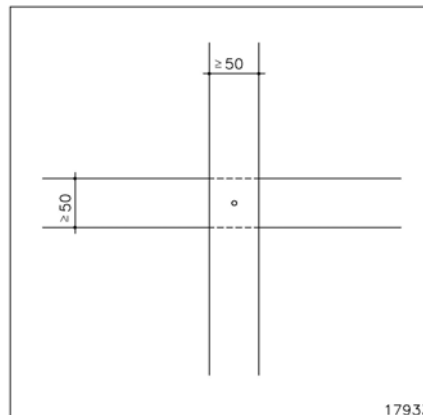

VERTICAL WOODEN SUPPORTING LATHS

The vertical wooden supporting laths are planed on one side and aligned in the same plane when placing to obtain sufficient evenness. The wood must also be sufficiently stable so that alignment is retained. A small expansion joint is left between the wooden supporting laths.

- maximum unevenness : $\leq L/1000$
- joint between supporting laths : $\geq 5\text{mm}$

The wooden supporting laths are placed vertically so that penetrating or condensation water can run down from the back of the panel (and does not stagnate on the wooden laths).

The wooden supporting laths must be sufficiently wide for sufficient water sealing and the correct fitting of the fastening accessories. At vertical joints it is recommended to use slightly wider wooden supporting laths than the minimum width to be able to accommodate tolerances in alignment (and therefore avoid "air screws").

	Minimum width of supporting lath
Supporting lath without joint finishing	$\geq 40\text{ mm}$
Supporting lath at a joint	$\geq 70\text{ mm}$

In some cases it can be preferable to work with supporting laths greater than or equal to 40mm with a widening at each joint using a block.

The supporting laths must be sufficiently thick to resist occurring forces and to enable the correct application of the fastening accessories of the CEDRAL.

Supporting laths fixed with adjustable brackets

- minimum thickness of the supporting laths: 50 mm
- Maximum distance between brackets : $\leq 1500\text{ mm}$

Supporting laths fixed on wooden cross laths

Distance between horizontal cross laths	Minimum thickness of the supporting laths	
	CEDRAL fixed with nails	CEDRAL fixed with screws
600 mm	$\geq 35\text{ mm}$	$\geq 30\text{ mm}$
800 mm	$\geq 35\text{ mm}$	$\geq 35\text{ mm}$
1000 mm	$\geq 40\text{ mm}$	$\geq 40\text{ mm}$
1200 mm	$\geq 45\text{ mm}$	$\geq 45\text{ mm}$
1500 mm	$\geq 50\text{ mm}$	$\geq 50\text{ mm}$

APPLICATION PROCEDURE

The following procedure can be used for the fitting of CEDRAL on a wooden supporting structure by means of adjustable brackets.

1. Check the straightness of the wooden laths
2. Use the facade cladding design plan to mark off the centre to centre distances between the supporting laths on the facade by means of a plumb-rule or a laser
3. Fit the adjustable brackets
4. Fit the supporting laths on the brackets
5. Align the supporting laths horizontally and vertically in a section by the gradual arrangement of the brackets (maximum unevenness is less than $L/1000$)
6. Fit the CEDRAL panels.

5 Fixing

CEDRAL can be nailed or screwed, manually or automatically. Fastening with screws offers the following advantages compared to fastening with nails:

- can be disassembled
- higher resistance to wind load
- fast installation using an automatic drill

Each CEDRAL must be fixed on each supportive supporting lath once. There must always be a supporting lath at the edge of a CEDRAL.

The following minimum distances from the edges of the fastening accessories must be respected.

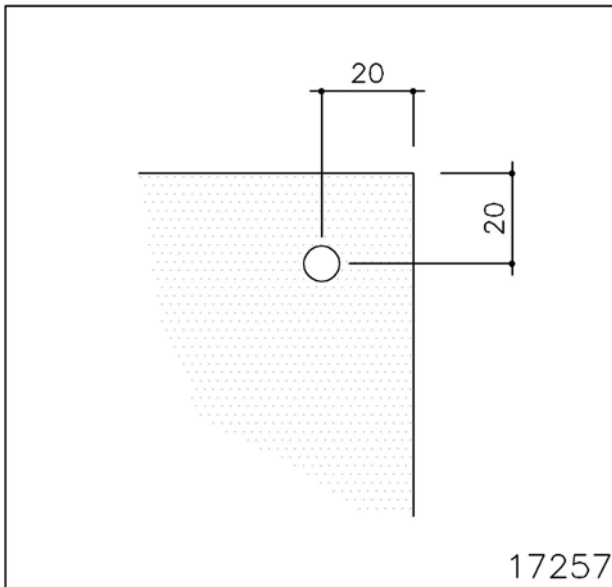

The fastening accessories must be applied perpendicularly to the fibre cement strip and in such a way that the CEDRAL is not noticeably distorted.

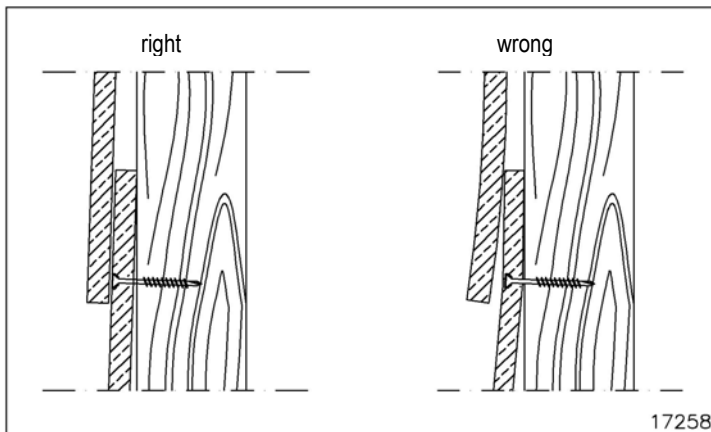

Application instructions

Cedral on a wooden supporting structure

Fastening with nails:

CEDRAL can be fixed with stainless steel (A2) ribbed nails with the following sizes.

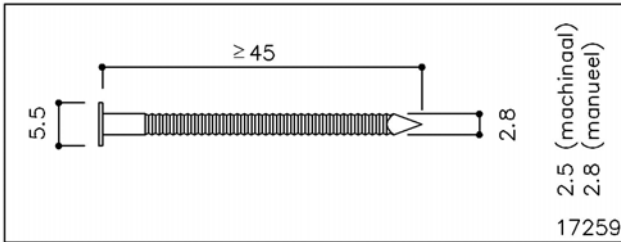

The following distances from the edge must be respected for the inserting of the nail in the wooden supporting lath.

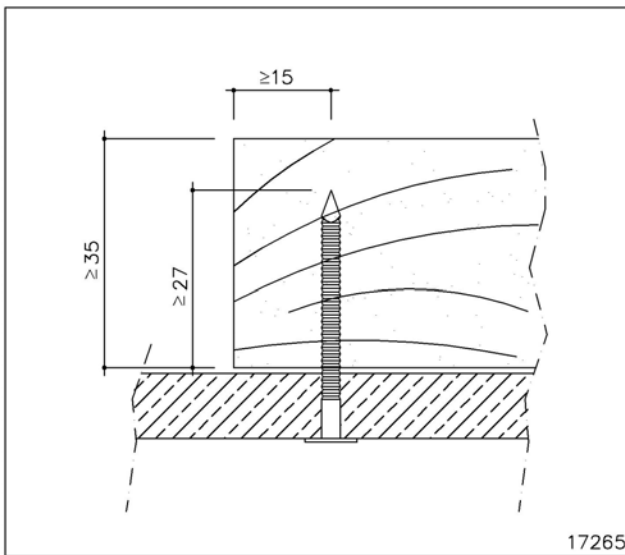

The head of the nail may not be driven into the CEDRAL. The pneumatic nailing machine is regulated with constant depth. If the nails are inserted by hand, the holes at the ends of the CEDRAL must be predrilled with a 2 mm diameter.

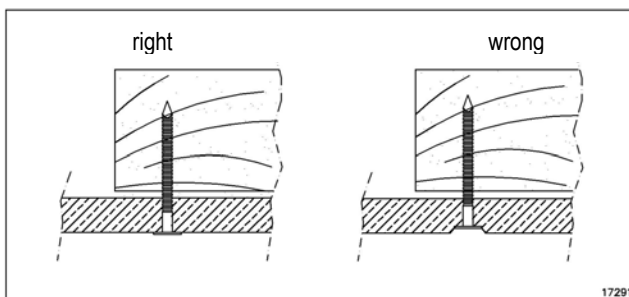

Application instructions

Cedral on a wooden supporting structure



Fastening with screws:

CEDRAL can be fixed with stainless steel (A2) screws with countersunk head with square drive with the following sizes. The screw head is provided with milling ribs and the screw has a special cutting point.

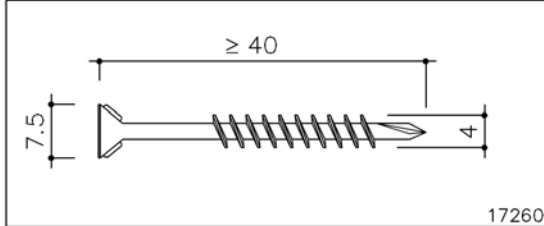

The following distances from the edge must be respected for the fastening of the screw in the wooden supporting lath.

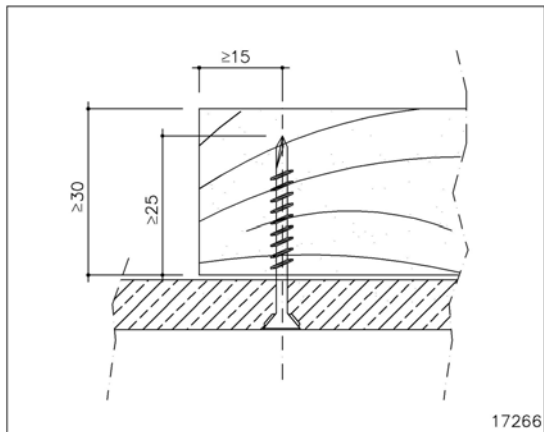

The screws are inserted using an electric drill with a high quality bit suitable for the type of screw head.

The head of the screw may not be driven too deep into the CEDRAL and may also not protrude.

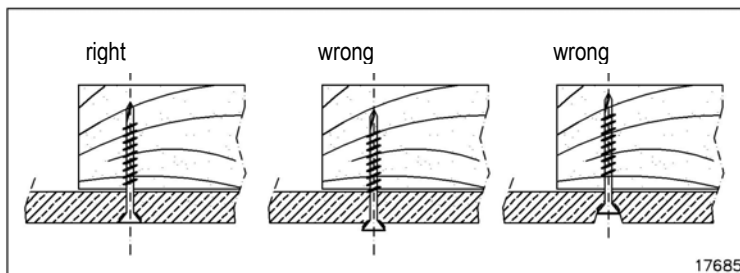

If the screws are visible one must use screws with a mushroom head. The screw is provided with a cutting point so the pre-drilling of the panel is not required.

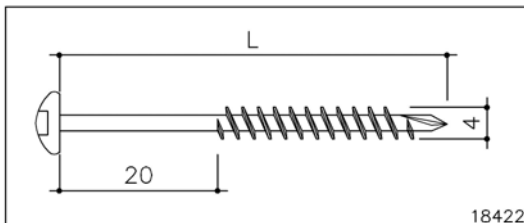

Panel thickness	Screw length
Single thickness e.g. Vertical application with open joints	$L \geq 42$ mm
Double thickness e.g. Alternating vertical application	$L \geq 52$ mm

6 Horizontal overlap application

For technical reasons the application with visible fixings of CEDRAL wood stain colours is not supported by EURO PANELS OVERSEAS N.V..

CEDRAL are fixed horizontally in a weather boarded (or overlapping or scale-like) way on vertical wooden supporting laths. Ventilation is provided between the vertical supporting laths (s).

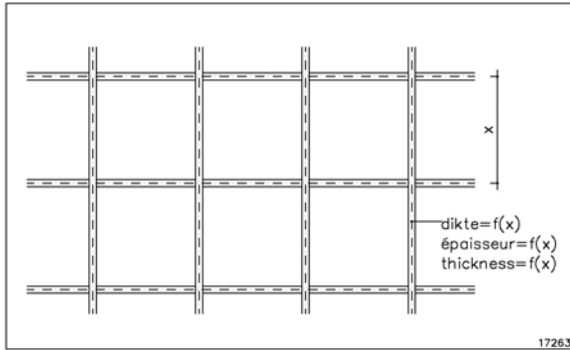

The following overlap patterns are possible.

- Straight pattern (for aesthetic reasons a joint of 5 to 10 mm is desirable)

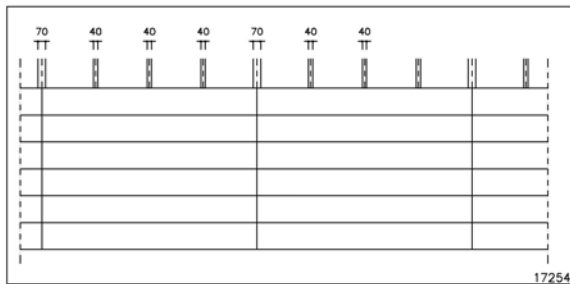

- Semi-pattern (the ends of the CEDRAL are placed against each other)

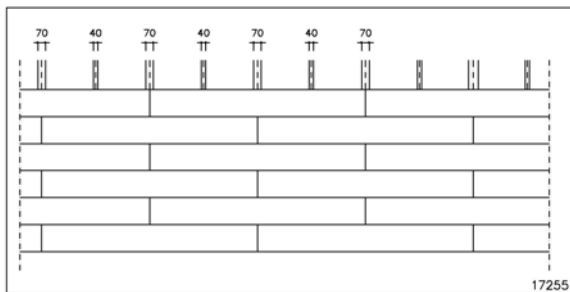

- Free pattern (the ends of the CEDRAL are placed against each other)

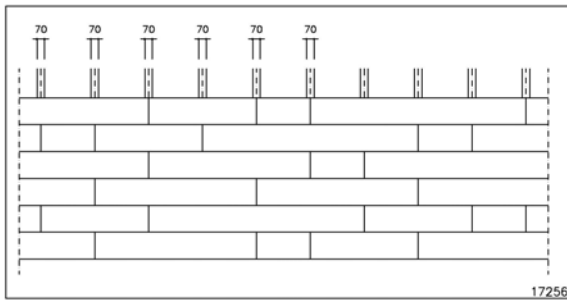

Assembly starts at the bottom of the outside wall where a starting strip (with the same thickness as the CEDRAL and with the same length of the overlap) is first applied. This is overlapped by the first CEDRAL that is accordingly placed at the correct angle (4° as standard). Another possibility is to start with an aluminium starting profile (painted in the same colour as the CEDRAL) that places the first CEDRAL in the correct angle.

- minimum horizontal overlap : 30 mm

Starting strip

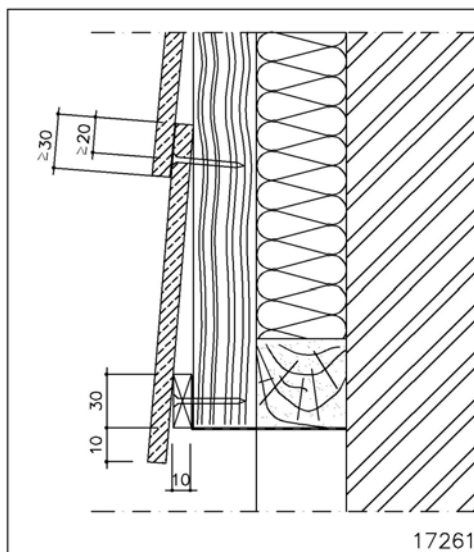

Starting profile

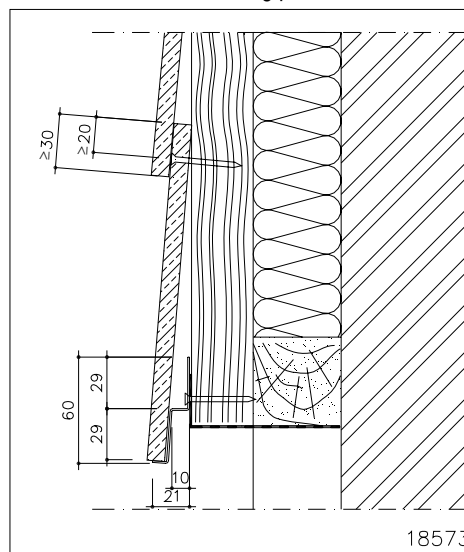

The CEDRAL are placed with the ends against each other and always on top of an underlying supporting lath. Behind the joints between the CEDRAL, the wooden supporting lath must be protected by a joint sealing strip with sufficient stiffness. Because the joint sealing strip is not exposed to light, a black polyethylene (PE) 0.5 mm-thick joint sealing strip is sufficient. If the joint sealing strip is exposed to light, a UV-resistant material such as EPDM must be used. The joint sealing strip is also applied in overlap to avoid the penetration of water and is fixed separately. For aesthetic reasons additional fastening at the bottom the CEDRAL along both sides of the joint is recommended.

- minimum overhang of joint sealing strip past supporting lath : 5 mm

Application instructions
Cedral on a wooden supporting structure

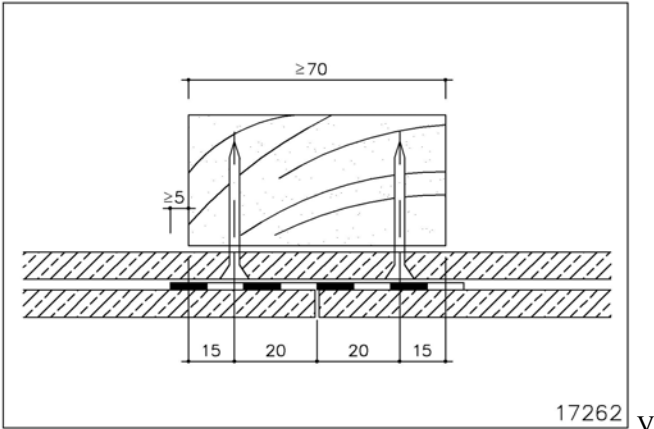

The maximum centre to centre distance between the fastening accessories is determined by the wind load and the strength characteristics of the CEDRAL and amounts to:

	Maximum centre to centre distance between the fastening accessories		
	Inland: 0-10 m	Inland: 10-20 m	Coast: 0-20 m
Centre area façade	600 mm	600 mm	500 mm
Edge area façade	500 mm	400 mm	400 mm + visible fastening
Single span	500 mm + visible fastening	400 mm + visible fastening	400 mm + visible fastening

Prefabricated elements may only be screwed or visibly nailed. The elements must be sufficiently rigid so that movements during transport (transportation, movements by crane) are restricted. Depending on the height of the building visible fastening is also required.

Invisible fastening with screws

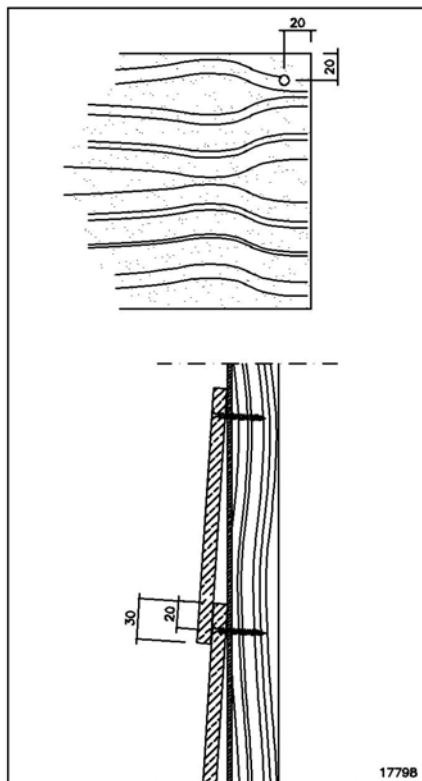

Visible fastening with nails

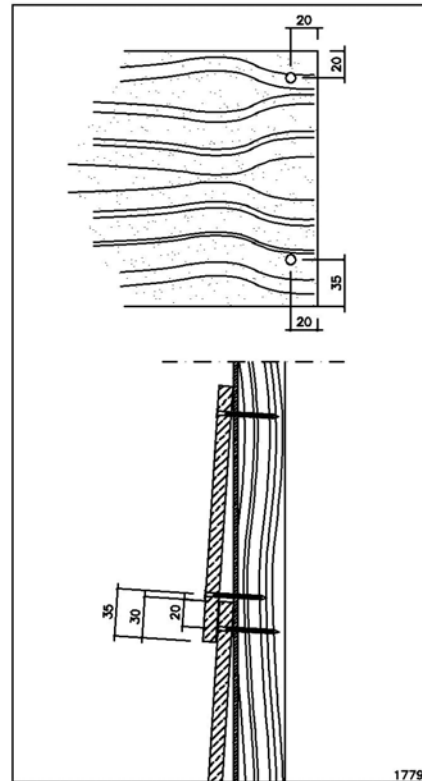

The consumption of material can be calculated for a continuous outside wall with CEDRAL with, for example, an overlap of 30 mm and a distance between the fastening accessories of 600 mm.

- CEDRAL CLASSIC used : 6.25 m²/m² or qty. 1.74/m²
- CEDRAL SMOOTH used : 6.25 m²/m² of qty. 1.74/m²
- fastening accessories used : qty. 12.5/m²
- joint sealing strip used : ± 0.4 m/m²

7 Horizontal overlap application with a highlighted shadow line

For technical reasons the application with visible fixings of CEDRAL wood stain colours is not supported by EURO PANELS OVERSEAS N.V..

CEDRAL are fixed horizontally in a weather boarded (or overlapping or scale-like) way on vertical wooden supporting laths. Ventilation is provided between the vertical supporting laths (s).

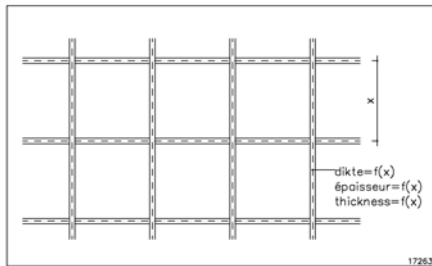

CEDRAL can be mounted in different overlap patterns (see horizontal overlap application).

On the vertical supporting laths horizontal beveled supports are nailed or screwed. The upper side of these supports needs to be inclined towards the cavity to avoid water stagnation behind the CEDRAL.

The thickness of the horizontal supports determines the inclination of the CEDRAL and also the width of the shadow line.

- minimum horizontal overlap : 30 mm

Mounting with 2nd visible fixing point
 (coated mushroom head screw)

Mounting with non visible 2nd fixing (glue)

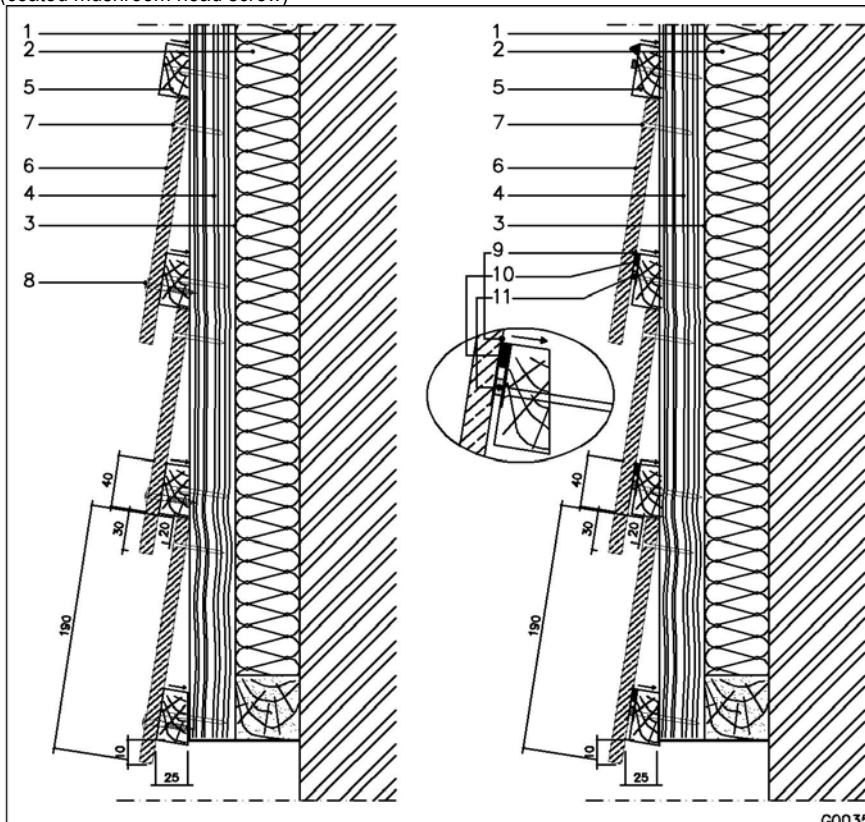

- 1 supporting wall
- 2 isolation
- 3 vapour open windscreen
- 4 vertical supporting laths
- 5 horizontal support
- 6 CEDRAL
- 7 Fixing means
- 8 2nd visible fixing point
- or non visible 2nd fixation
- 9 Surface improver
- 10 Glue
- 11 Double sided adhesive strip

The CEDRAL are fixed 2 times on each vertical supporting lath, one countersunk screw underneath the overlap and one visible screw with a coated mushroom head in the horizontal support.

As an alternative the lower part of the CEDRAL can also be fixed with a non visible fixing with glue. Water stagnation on the glue between the CEDRAL and the wooden support needs to be avoided. This can be achieved by applying the glue as high as possible on the wooden support and by interrupting the glue for example every 600 mm. Beneath the glue a double sided self adhesive strip is applied. This strip has a triple function; temporary fixing until hardening of the glue, distance keeper (the CEDRAL can not be pushed to deep in the glue) and sealing strip (glue can not run down from behind the CEDRAL).

Bonding must always take place in accordance with the conditions of the supplier of the bonding system and under his supervision and guarantee conditions.

- Always consult the complete gluing advice of the manufacturer of the glue!
- An excellent quality of the glue can only be obtained by strictly following these instructions.
- Always work with certified products (KOMO, ATG or equivalent), tested on Euro Panels Overseas N.V. material.

The maximum centre to centre distance between the fastening accessories is determined by the wind load and the strength characteristics of the CEDRAL and amounts to:

	Maximum centre to centre distance between the fastening accessories		
	Inland: 0-10 m	Inland: 10-20 m	Inland: 0-10 m
Centre area façade	600 mm + visible fixing or gluing	600 mm + visible fixing or gluing	500 mm + visible fixing or gluing
Edge area façade	500 mm + visible fixing or gluing	400 mm + visible fixing or gluing	400 mm + visible fixing or gluing
Single span	500 mm + visible fixing or gluing	400 mm + visible fixing or gluing	400 mm + visible fixing or gluing

The consumption of material can be calculated for a continuous outside wall with CEDRAL with, for example, an overlap of 30 mm and a distance between the fastening accessories of 600 mm.

- CEDRAL CLASSIC used : 6.25 m/m² or qty. 1.74/m²
- CEDRAL SMOOTH used : 6.25 m/m² of qty. 1.74/m²
- fastening accessories used : qty. 12.5/m²
- joint sealing strip used : ± 0.4 m/m²

8 Alternating vertical application

For technical reasons the vertical application of CEDRAL wood stain colours is not supported by EURO PANELS OVERSEAS N.V..

Two layers of CEDRAL are fixed overlapping on horizontal wooden supporting laths. Ventilation is provided between the vertical wooden cross laths.

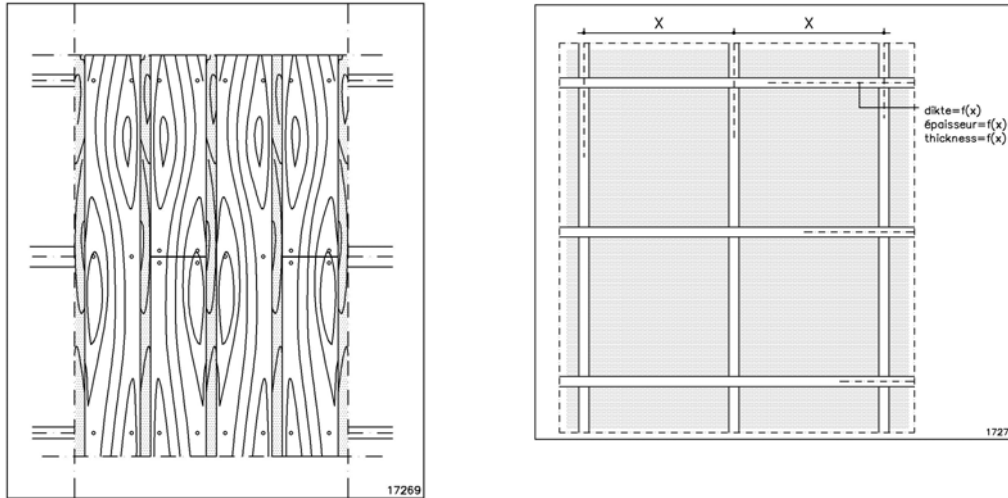

Half-cut CEDRAL are first placed on the horizontal supporting laths using two fastening accessories per underlying lath. The ordinary CEDRAL are then fitted on top with two fastenings per underlying lath. Here the open joint coincides with the underlying CEDRAL. The CEDRAL are placed with the ends against each other and always on top of an underlying supporting lath. Pre-drilling with a 2mm diameter is required with manual nailing through two CEDRAL. Because of the large number of visible nails it is recommended to fully coat the fitted CEDRAL in place or using screws with coloured truss head. The insulation is protected by a watertight vapour permeable windscreen.

- width open joint : 35 mm
- overlap : 30 mm
- distance from edge fastener : 15 mm
- minimum length of nails/screw : 50 mm / 50 mm

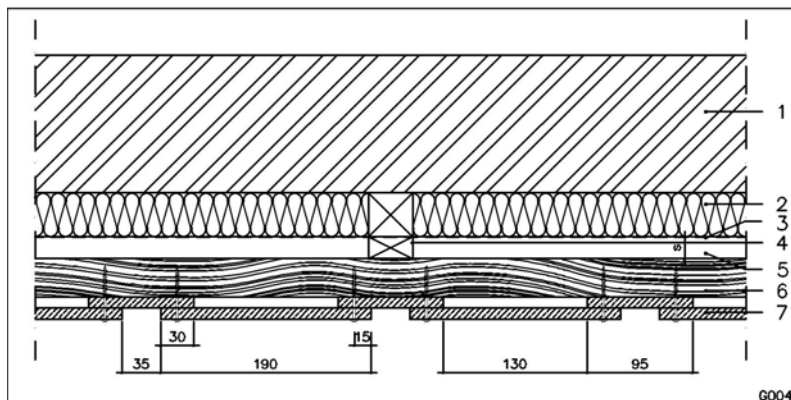

- 1 supporting wall
- 2 isolation
- 3 vapour open windscreen
- 4 vertical supporting laths
- 5 cavity(s)
- 6 horizontal supporting laths
- 7 CEDRAL

The maximum centre to centre distance between the fastening accessories is determined by the wind load and the strength characteristics of the CEDRAL and amounts to:

	Maximum centre to centre distance between the fastening accessories		
	Inland: 0-10 m	Inland: 10-20 m	Coast: 0-20 m
Centre area façade	600 mm	600 mm	500 mm
Edge area façade	500 mm	400 mm	400 mm
Single span	500 mm	400 mm	400 mm

The consumption of material can be calculated for a continuous outside wall with CEDRAL with, for example, an overlap of 30 mm and a distance between the fastening accessories of 600 mm.

- CEDRAL CLASSIC used : qty. 1.85/m²
- CEDRAL SMOOTH used : qty. 1.85/m²
- fastening accessories used : qty. 17.3/m²

Other constructions are possible, e.g.

- two CEDRAL alternating with a joint width of 130mm

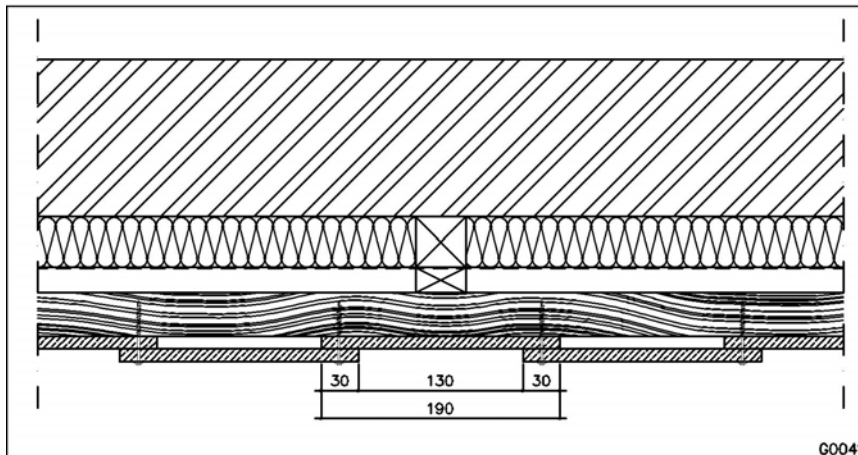

- CEDRAL CLASSIC used : qty. 1.74/m²
- CEDRAL SMOOTH used : qty. 1.74/m²
- fastening accessories used : qty. 12.2/m²

9 Vertical overlap application

For technical reasons the vertical application of CEDRAL wood stain colours is not supported by EURO PANELS OVERSEAS N.V..

CEDRAL are fixed vertically in a weather boarded (or overlapping or scale-like) way on horizontal wooden supporting laths. Ventilation is provided between the vertical wooden cross laths.

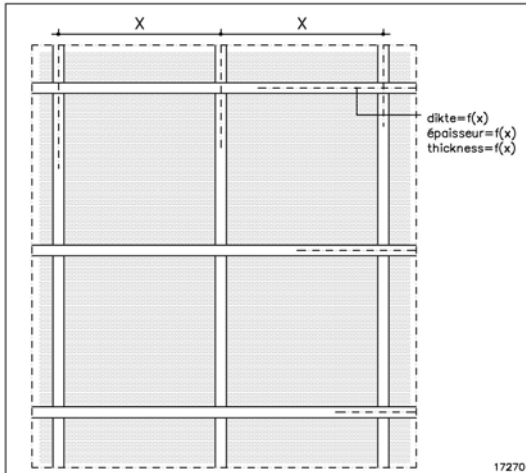

Assembly starts with a starting strip (with the same thickness as the CEDRAL and with the same height as the overlap). This starting strip is overlapped by the first CEDRAL that is accordingly placed at the correct angle (4° as standard).

Pre-drilling with a 2mm diameter is required with manual nailing through two CEDRAL. Because of the large number of visible nails it is recommended to fully coat the fitted CEDRAL in place or using screws with coloured truss head. The insulation is protected by a watertight vapour permeable windscreen.

- overlap : 30 mm
- distance from edge fastener : 15 mm
- minimum length of nails/screw : 50 mm / 50 mm

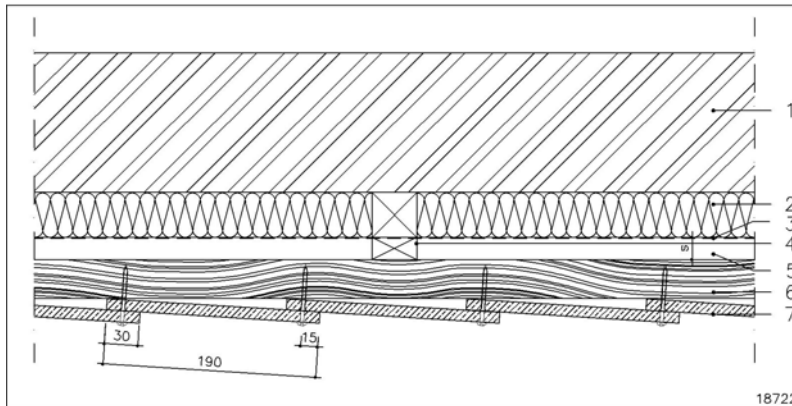

- 1 supporting wall
- 2 isolation
- 3 vapour open windscreen
- 4 vertical supporting laths
- 5 cavity (s)
- 6 horizontal supporting laths
- 7 CEDRAL

The maximum centre to centre distance between the fastening accessories is determined by the wind load and the strength characteristics of the CEDRAL and amounts to:

	Maximum centre to centre distance between the fastening accessories		
	Inland: 0-10 m	Inland: 10-20 m	Coast: 0-20 m
Centre area façade	600 mm	600 mm	500 mm
Edge area façade	500 mm	400 mm	400 mm
Single span	500 mm	400 mm	400 mm

The consumption of material can be calculated for a continuous outside wall with CEDRAL with, for example, an overlap of 30 mm and a distance between the fastening accessories of 600 mm.

- CEDRAL CLASSIC used : 6.25 m²/m² or qty. 1.74/m²
- CEDRAL SMOOTH used : 6.25 m²/m² of qty. 1.74/m²
- fastening accessories used : qty. 12.5/m²

To avoid water infiltration, the prevailing wind should be taken into consideration to determine the direction of the overlap.

10 Vertical application with open joints

For technical reasons the vertical application of CEDRAL wood stain colours is not supported by EURO PANELS OVERSEAS N.V..

The CEDRAL are placed vertical on underlying vertical wooden supporting laths with an open joint. Ventilation is provided between the vertical supporting laths.

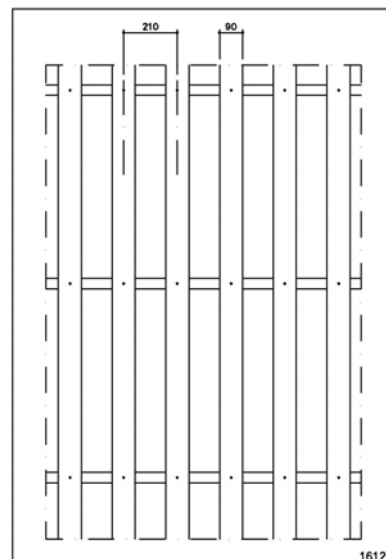
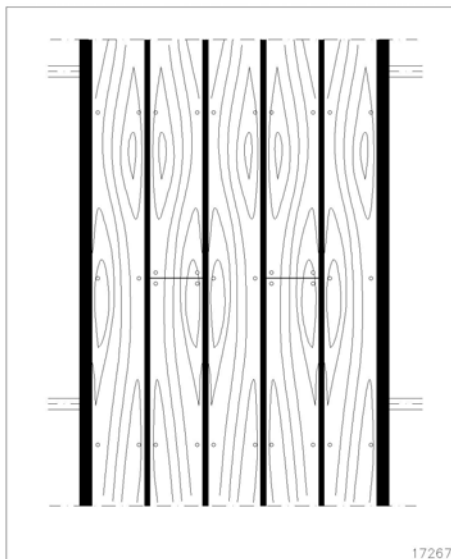

The wooden supporting laths are of weather-resistant hardwood, or they must be protected against weather influences by a weather-resistant coating or a UV-resistant EPDM joint sealing strip. The CEDRAL are then fitted on top with two fastenings per underlying lath. Here the open joint coincides with the underlying supporting lath. The CEDRAL are placed with the ends against each other and always on top of an underlying supporting lath. Because of the large number of visible nails it is recommended to fully coat the fitted CEDRAL in place or using screws with coloured truss head. The insulation is protected by a watertight vapour permeable windscreen.

- minimum width of vertical supporting lath : 90 mm
- centre to centre distance between supporting lath : 210 mm
- width open joint : 20 mm
- minimum length of nails/screw : 40 mm/35 mm

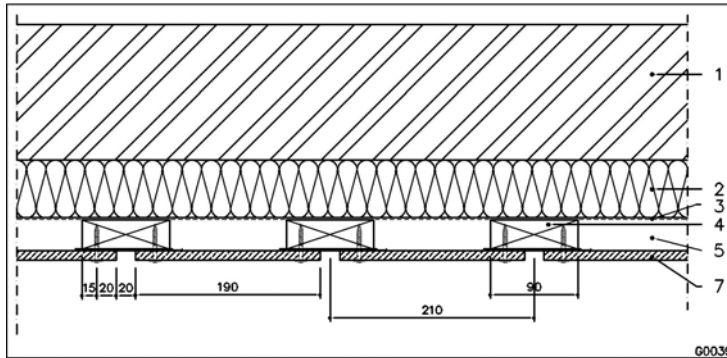

- 1 supporting wall
- 2 isolation
- 3 vapour open windscreen
- 4 vertical supporting laths
- 5 cavity (s)
- 6 horizontal supporting laths
- 7 CEDRAL

The maximum centre to centre distance between the fastening accessories is determined by the wind load and the strength characteristics of the CEDRAL and amounts to:

	Maximum centre to centre distance between the fastening accessories		
	Inland: 0-10 m	Inland: 10-20 m	Coast: 0-20 m
Centre area facade	600 mm	600 mm	500 mm
Edge area facade	500 mm	400 mm	400 mm
Single span	500 mm	400 mm	400 mm

The consumption of material can be calculated for a continuous outside wall with CEDRAL with, for example, an open joint of 20 mm and a distance between the fastening accessories of 600 mm.

- CEDRAL CLASSIC used : qty. 1.32/m²
- CEDRAL SMOOTH used : qty. 1.32/m²
- fastening accessories used : qty. 18.5/m²
- joint sealing strip used : 4.76 m/m²

Other constructions are possible, e.g.
- use variation in the joint width

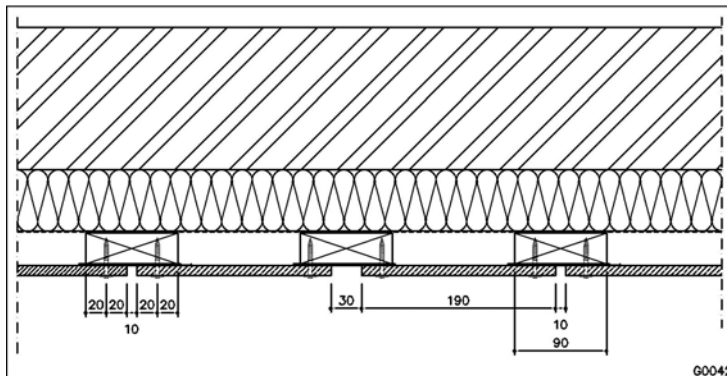

11 Curved horizontal application in overlap

CEDRAL in a curved construction are fixed with screws. The screws are not tightened too much so the CEDRAL is evenly bent. The ends are slightly shortened and rounded so that they fit against each other. The minimum bend radius is 12 m.

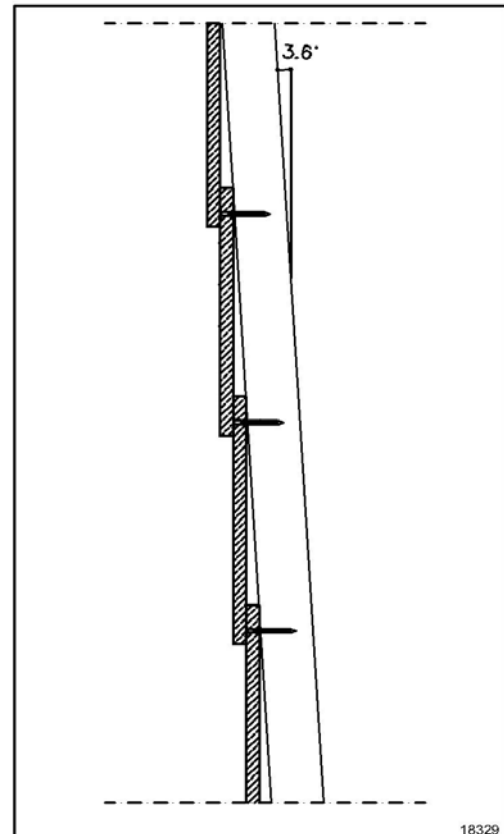
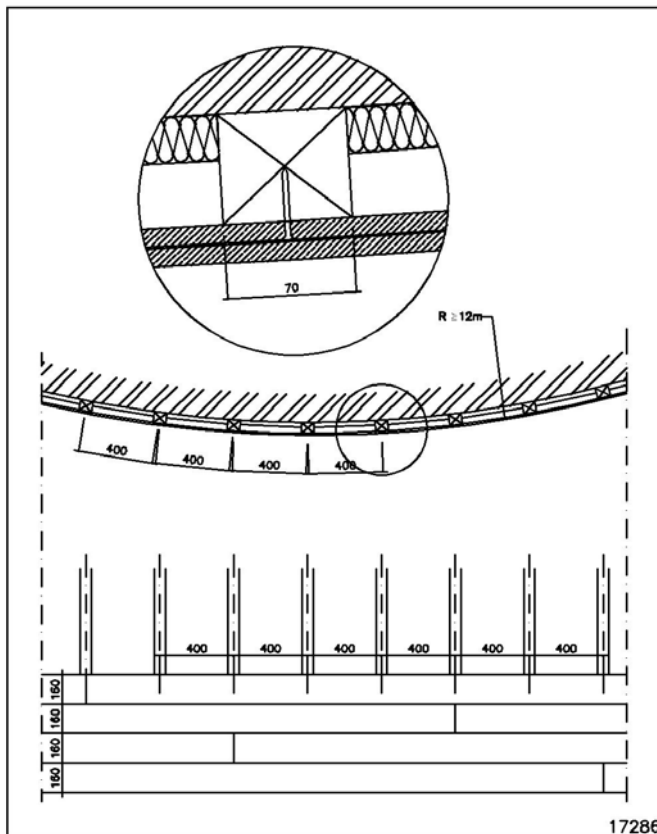

It is also recommended to have the wall incline slightly (3.6°) in such a way that the bent CEDRAL are not twisted.

12 Expansion joints

Surface expansion joints are provided according to the maximum expansion of the cladding system. Different options are possible:

- 1 Installing Cedral next to each other without joints: expansion joint of 10 mm every 20 m.
- 2 Installing Cedral with 2 to 3 mm joints: no further expansion joints necessary.
- 3 Installing Cedral next to each other without joints for facades up to 20 m in length: leave a 5 mm margin at the end and/or corner profiles.

Structural expansion joints in the back construction are always to be included in the cladding.

13 Soffit / ceiling covering

The CEDRAL are placed horizontally and fixed with nails or screws on a wooden frame. The CEDRAL can be fitted against each other in both directions with a small open joint of 2 mm. The CEDRAL is fixed with two visible fastening accessories on each supporting wooden strip. If necessary damp-open film must also be provided against rain infiltration.

- distance between fixing points : 400 mm

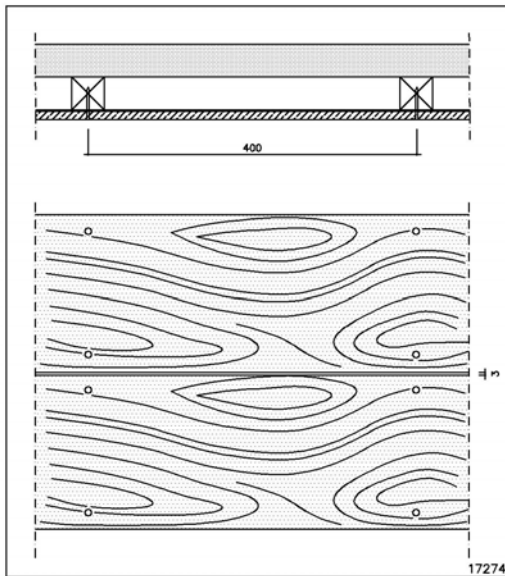

14 Shack

Because of a high impact risk in this application, the maximum distance between the vertical wooden supporting laths is 400 mm and it is strongly advised to fix a rigid water-resistant panel first on the wooden substructure (for example MENUISERITE DG or ETERBOARD MD, depending on the strength requirements).

EURO PANELS OVERSEAS N.V. advises to fix the CEDRAL in this application with invisible fixation with screws or with visible fixation with nails.

Invisible fixing with screws

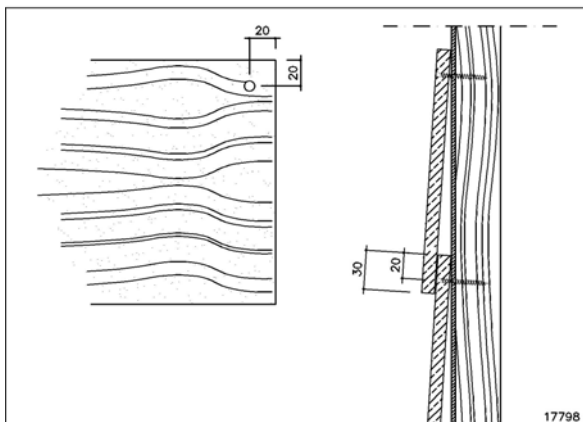

Visible fixing with nails

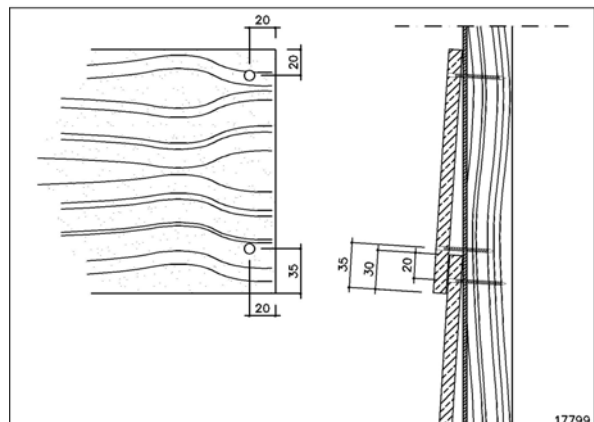

15 Accessories¹

The following accessories can be obtained from EURO PANELS OVERSEAS N.V..

CEDRAL screw	Stainless steel	4,2 x 45 mm
CEDRAL nail	Stainless steel	2,8 x 45 mm
Mushroomhead screw with wings	Coated stainless steel	4,8 x 38 mm
Perforated sealing profile	Blank aluminium	50 x 30 x 2500 mm
Perforated sealing profile	Blank aluminium	70 x 30 x 2500 mm
Perforated sealing profile	Blank aluminium	100 x 30 x 2500 mm
Symmetrical outer corner profile	Coated aluminium	35 x 25 x 30 x 25 x 3000 mm
Asymmetrical outer corner profile	Coated aluminium	35 x 10 x 30 x 25 x 3000 mm
Connection profile for outer corner profile	Black coated aluminium	Lengte 300 mm
Inner corner profile	Coated aluminium	25 x 25 x 3000 mm
Endprofile	Coated aluminium	8 x 27 x 45 x 3000 mm
Connection profile window	Coated aluminium	8 x 15 x 45 x 3000 mm
Start profile	Coated aluminium	30 x 10 x 30 x 9 x 3000 mm
Joint profile	PE	100 x 0,5 mm
Joint profile (UV resistant)	EPDM	100 x 0,75 mm
Touch up paint		0,5 L
CEDRAL installation tool (set of 2)	Aluminium	
CEDRAL shears	Metal	

- Coated aluminium body provided with an adjustable Teflon support and a toggle clamp. Overlap is adjustable so that the visible part of the CEDRAL can vary from approximately 155 mm to 170 mm. By adjusting the installation tool the visible part of the CEDRAL can vary to obtain an optimum partition of the CEDRAL panels on the facade.

Instruction for use:

- Set the tools to the desired overlap by adjusting the Teflon support of the tool. Make sure both tools are set identical.
- Always use 2 installation tools to simplify the mounting.
- Stick the tool under the CEDRAL already installed.
- Tighten the toggle clamp to the surface of the CEDRAL.
- Put the next CEDRAL on the installation tools.
- Fasten this CEDRAL with screws or nails respecting the minimum edge distance of 20 mm.
- Loosen and take away the installation tools and proceed with the next CEDRAL.
- Repeat this procedure for the next CEDRAL.

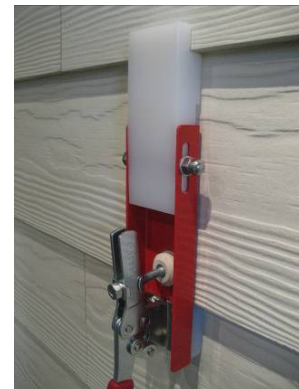

- CEDRAL shears to cut CEDRAL panels to length in a quick and easy way without producing any dust.

¹ Use Euro Panels Overseas N.V. accessories; not using standard Euro Panels Overseas N.V. accessories may lead to cancellation of the Euro Panels Overseas N.V. guarantee.

Instruction for use:

- The shears should be placed on a steady underground.
- The CEDRAL is placed on the shears front side up.
- The CEDRAL must be put against the stopper to have a square cut.
- Long CEDRALs must eventually be supported by the enclosed support.
- The CEDRAL can be cut in one single move.
- If necessary the sawed edges can be smoothed with fine emery cloth or a sanding block.



16 Detail drawings

Detail finishing is provided in such a way that no tension is exerted on the CEDRAL. This implies that the free expansion may not be obstructed by the aluminium finishing profiles and that a little margin (2 mm) between the profiles and the CEDRAL is advised.

Finishing sections in metals that can leach (such as zinc, copper, lead, etc.) are advised against because of possible soiling.

The following detail drawings are available by way of example for the horizontal overlap application:

OUTER CORNER: Corner finishing can be provided by means of a joint sealing strip or a finishing profile of aluminium.

INNER CORNER: A joint sealing strip or finishing profile in aluminium can also be used here.

BOTTOM FINISHING: The open cavity between the back of the CEDRAL and the insulation or the back construction must be sealed at the bottom by a perforated aluminium sealing profile. This profile prevents the entry of birds and vermin. The raised leg of the sealing profile is clamped between the wooden supporting lath and the CEDRAL. A starting strip is provided for the bottom CEDRAL in such a way that it is at the same angle as the other CEDRAL.

TOP FINISHING: Sufficient ventilation openings must be provided.

WINDOW FINISHING WITH RETURN: Sufficient ventilation openings must be provided at the top and bottom of the window.

WINDOW FINISHING WITHOUT RETURN: Sufficient ventilation openings must be provided at the top and bottom of the window.

SURFACE-MOUNTED WINDOW

ROUND WINDOW: The return section can be provided in the same material as the window. The bottom of the return section is provided with a fitting to prevent drip lines on the CEDRAL. The CEDRAL are finished around the window using a fretsaw and can be finished with a cover profile.

EXPANSION JOINT: The expansion joints in the building must also be included in the cladding. They are obtained by placing an aluminium profile on both sides of the joint.

17 Information on external suppliers

The following manufacturers dispose of specific advices and warranty declarations.

Mushroom head screw	Mage	Mage fasteners B.V. 0031 (0)321 38 70 40 www.magefasteners.nl
Glue	SIKA	Sika NV 0032 (0)2 726 16 85 www.sika.be
	Tweha	Tweha B.V. 0032 (0)70 246 009

Collated nails and screws	SENCO	Cerclindus NV 0032 (0)3 355 03 20 fastening@cerclindus.be
Sawing blade	LEITZ	N.V. Leitz-Service S.A. 0032 (0)2 756 02 34 www.leitz-service.be
Sawing blades	BOSCH	www.bosch-pt.be
Hole saw	METABO	www.metabo.be

18 Health and safety aspects

During the mechanical machining of panels, dust can be released which can irritate the airways and eyes. Apart from this, the inhalation of fine (respirable size) quartz containing dust, particularly when in high concentrations or over prolonged periods of time can lead to lung disease and an increased risk of lung cancer. Depending on the working conditions, adequate machinery with dust extraction and/or ventilation should be foreseen. For more ample information, please check the Safety Data Sheet according to 91/155/EEC.

19 More information

Information about the various cladding panels can be found in the EURO PANELS OVERSEAS N.V. product information sheets. They can be found on the website or can be obtained on demand by phone. Information about external suppliers can also be downloaded from the website.

These application instructions replace any previous editions. EURO PANELS OVERSEAS N.V. reserves the right to amend these instructions without prior notice. Readers should always satisfy themselves that they are referring to the most recent version of this document. No part of this text can be changed without permission of EURO PANELS OVERSEAS N.V..

EURO PANELS OVERSEAS NV,

p.o. Central Services
Kuiermansstraat 1
B-1880 Kapelle-op-den-Bos
Belgium

Tel 0032 (0)15 71 73 80

Fax 0032 (0)15 71 73 89

info@europanels.be

www.europanels.be



Registered office address: Bormstraat 24, B-2830 Willebroek - BELGIUM
RPR 0 466 056 888, Mechelen – VAT BE 0 466 056 888 – Bank account nr. 482-9098051-96