

Ventilated façade

1 General

These application instructions are specifically intended for the fastening of large-size EURO PANELS OVERSEAS N.V. façade panels as outside wall cladding on a ventilated and insulated structure in stainless steel, fixed to a back construction. A number of basic principles are given that must be adhered to. For variations or additional advice one can always contact EURO PANELS OVERSEAS N.V..

2 Cladding material

The following EURO PANELS OVERSEAS N.V. products are treated in this document.

• ETER-COLOR	8 mm
• OPERAL	9 mm

Product data and processing information can be found in the product information sheets, available from EURO PANELS OVERSEAS N.V..

For façade or ceiling applications only rectified boards may be used, non-rectified boards should not be used uncut.

3 Area of application

These instructions apply for buildings up to a certain height and subjected to a maximum actual wind load in a certain wind zone. The maximum intermediate distance of the supporting structure is determined in relation to the occurring wind load taking into account a safety factor. The table below only shows non-binding reference values for the wind loads. The exact values can be found in the standards NBN B 03-002-1; NEN 6702:2001 and NBN-EN 1991-1-4.

Location	Building height	Middle area façade		Edge area façade and single span	
		Max. actual wind load	Max. center-to-center distance supporting laths	Max. actual wind load	Max. center-to-center distance supporting laths
Wind zone	m	N/m ²	mm	N/m ²	mm
Land	0-10	650	600	1000	500
Land	10-20	800	600	1200	500
Land Coast	20-50 * 0-20	1000	500	1500	400

* The fixing of OPERAL to a building height higher than 20 m is not advised.

The width of the edge area amounts to at least 1 m from the corner of the building and must be further determined on the basis of prevailing national standards and conditions. If variations of the aforementioned load limits occur (e.g. due to certain location or form factors, etc.), the design must be determined by building services engineers.

When the façade panels are exposed to weather conditions (rain, sun) they may only be assembled on a vertical or leaned over supporting structure. For ceiling applications reference is made to the relevant application guidelines.

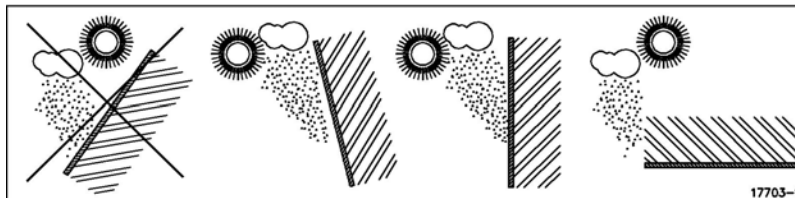

These instructions are only valid for applications in Europe, for applications outside of Europe the Technical Service Centre of Euro Panels Overseas N.V. should be consulted.

4 Patterns with large-size façade panels

The following patterns are possible. For aesthetic reasons, use rectified panels only.

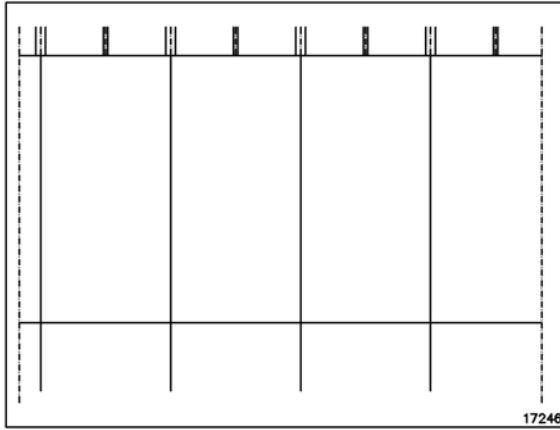

Straight pattern
with vertical panels

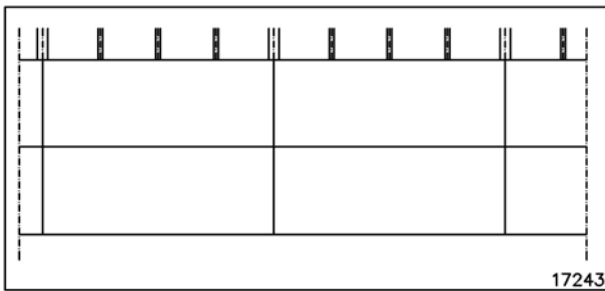

Straight pattern
with horizontal panels

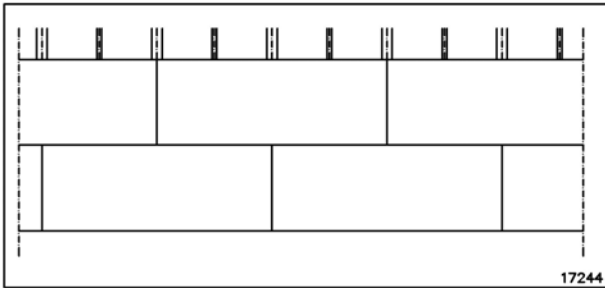

Semi pattern
with horizontal panels

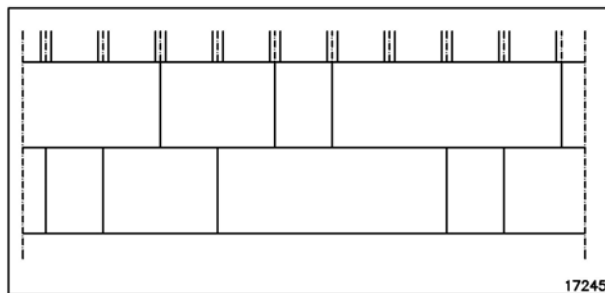

Free pattern
with horizontal panels

NOTE: semi pattern and free pattern are only advised for dark colours.

5 Supporting structure

The design and dimensions of the supporting structure in relation to the load fall under the guarantee conditions of the supplier of the supporting structure. This document only explains a number of general principles.

The EURO PANELS OVERSEAS N.V. large-size façade panels are fixed on vertical stainless steel supporting profiles. The vertical supporting profiles are fixed at a certain distance (depending on the required insulation thickness and air cavity) on the back construction by means of aluminium adjustable brackets.

The supporting structure must be able to resist the wind forces exerted on the building and the load of its own weight.

- maximum buckle under the influence of strain : $\leq \text{span}/300$
- safety factor calculation of strength : 3

All parts of the supporting structure are made of stainless steel.

The fastening of EURO PANELS OVERSEAS N.V. façade panels must always take place with a ventilated cavity. The necessary openings are provided on the bottom side, top side and in the details to allow sufficient ventilation.

Badly ventilated façade panels could result in physical problems for the construction and differences in colours under influence of humidity for panels with a semi-transparent coating.

- ventilation openings above/below : $\geq 10 \text{ mm/m}$ or $100 \text{ cm}^2/\text{m}$

Building height	0-10 m	10-20 m	20-50 m
Minimum cavity width	20 mm	25 mm	30 mm

Mineral wool with a water-repellent black protective coating is recommended for insulation. The insulation is fixed with synthetic insulation fastenings. The insulation is fastened according to the instruction of the producer of the insulation, e.g. with five insulation fasteners per square metre.

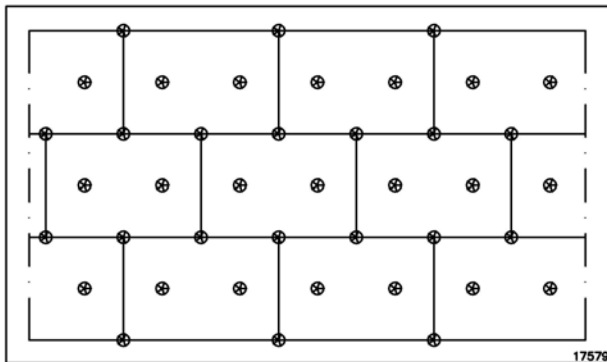

If the supporting profiles are fixed with brackets, the insulation is fastened after the fitting of the brackets and before the fitting of the supporting profiles. A slit is cut in the insulation at the bracket.

It is preferable to isolate the bracket from the supporting wall by using a piece of hard insulation material.

A. SUPPORTING BRACKET

The stainless steel supporting brackets allow the gradual varying of the distance between structural work and rear of the panel. This means an air cavity can be provided, insulation can be placed, and any unevenness of the rear wall can be eliminated.

There are different types of supporting brackets depending on the supplier of the supporting structure. In this document the supporting brackets are diagrammatically represented as follows.

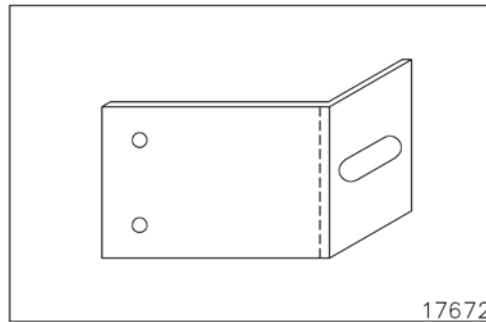
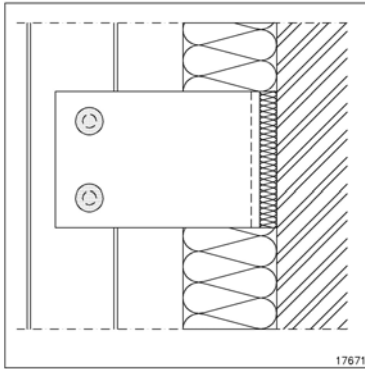

The distance between the brackets is determined by the load exerted (as a result of the wind load and force of gravity) and the strength properties of the stainless steel sections (to be indicated by the supplier of the stainless steel supporting structure). The calculation of the wind load has to be done according to the national applying standards (NBN B 03-002-1; NEN 6702:2001 ; NBN-EN 1991-1-4).

The fixing of the adjustable brackets to the back construction is individually determined for each project depending on the nature and the state of the wall to be claded.

In general a minimum pull-out value per fixing point of 3 kN (300kg) is recommended. This must however be verified for each project. For concrete and solid brick a stainless steel wood screw (min. 7 mm diameter) with a hexagonal head and associated nylon plug is used. The screws with hexagonal head are, however, not tightened too firmly so thread in the nylon plug is not damaged.

For other surfaces (hollow brick, cellular concrete, system walls, etc.) suitable fastening means must be used to be able to accommodate the tractive force occurring as a result of the wind load and the shearing forces as a result of the own weight. If necessary a pull-test must be conducted on site. An insulation block can be placed between the bracket and the back construction to prevent thermal bridges.

To obtain a stable supporting structure, the supporting brackets can alternately be fitted left and right of the stainless steel section. With uneven back constructions the bracket must be bent straight so the stainless steel sections not are twisted.

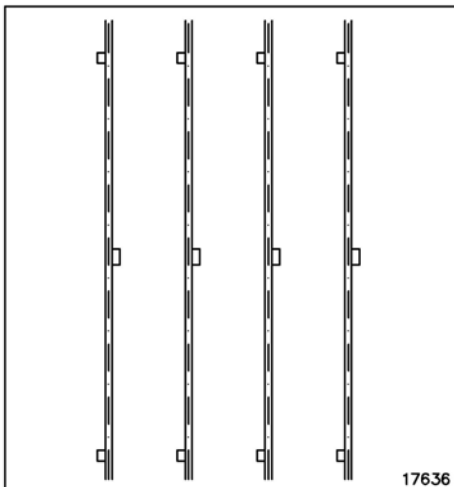

B. ALUMINIUM SUPPORTING PROFILES

There are different types of stainless steel sections depending on the supplier of the supporting structure. In this document the stainless steel section are diagrammatically represented as follows.

- Ω -section: at the vertical joints between the facade panels
- U-section: middle support

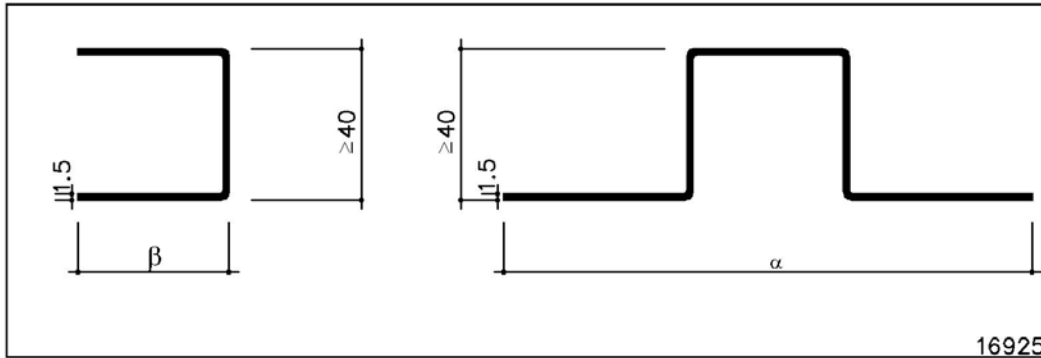

The vertical stainless steel sections and the surface they form must be sufficiently even.

- maximum unevenness : $\leq L/1000$

The aluminium supporting profiles are placed vertically so that penetrating or condensation water can run down from the back of the panel. The design plan of the façade cladding shows the supporting profiles.

The aluminium supporting profiles must be sufficiently wide for sufficient water sealing and the correct fitting of the fastening accessories. At vertical joints it is recommended to use slightly wider supporting profile than the minimum width to be able to accommodate tolerances in alignment (and therefore avoid "air rivets").

Fixing accessory	glue	rivet
Minimal width supporting profile without joint (β)	≥ 40 mm	≥ 40 mm
Minimal width supporting profile with joint (α)	≥ 100 mm	≥ 120 mm
Advised width supporting profile with joint (α)	100 mm	140 mm

Depending on the spans (to be indicated by the supplier of the stainless steel supporting structure) the stainless steel sections must be sufficiently thick to stand occurring loads (as a result of the wind load and force of gravity). The stainless steel section must also be sufficiently thick to allow the sufficiently strong fastening of the fastening accessories.

- minimum thickness stainless steel section : 1.5 mm

The length of the stainless steel sections is restricted to avoid too great expansion.

- maximum length stainless steel section : 4.0 m

C. FIXING SYSTEM PROFILE – SUPPORTING BRACKET

The fastening points must be strong enough to accommodate the own weight and the wind loads.

The fastening points can be arranged in different ways according to the supplier of the supporting structure:

- stainless steel rivets
- stainless steel bolts

The number of fastening points is determined in view of the loads occurring.

Expansion joints must be provided between the vertical stainless steel sections (fit a supporting bracket on both sides of the joint).

- width of joint between stainless steel sections : 10 mm

D. APPLICATION PROCEDURE

The following procedure can be used for the fitting of large-size façade panels by means of rivets on a stainless steel supporting structure.

1. Use the façade cladding design plan to mark off the centre to centre distances between the supporting profiles on the façade by means of a plumb-rule or a laser
2. Fit the brackets
3. Fit the supporting profiles on the brackets and align the supporting profiles horizontally and vertically in a section by the gradual arrangement of the brackets (maximum unevenness is less than L/1000)
4. Fix the stainless steel profiles
5. Fit the EURO PANELS OVERSEAS N.V. large-size façade panels. One starts at the top of and fits the panels using a metal lath with straight edge that are clamped on the supporting laths. Damaging the panel is avoided by assembling from top to bottom. Calibrated plates can be used to assemble the panels with the correct joint width. To obtain an attractive result it is best to minimise the tolerance of the vertical joints compared to the tolerance of the horizontal joints.
6. The calibrated plates have to be removed carefully, so that the sheet edges are not damaged.

E. POINTS OF PARTICULAR ATTENTION: INTERACTION OF SUPPORTING STRUCTURE AND FAÇADE CLADDING

When designing the supporting structure for the outside wall cladding it is very important that movements of the stainless steel sections can be accommodated by the façade cladding system, and not result into tension in the façade cladding sheets.

A joint between the stainless steel sections must always coincide with a joint between the panels. The joint is preferably continued at the same height.

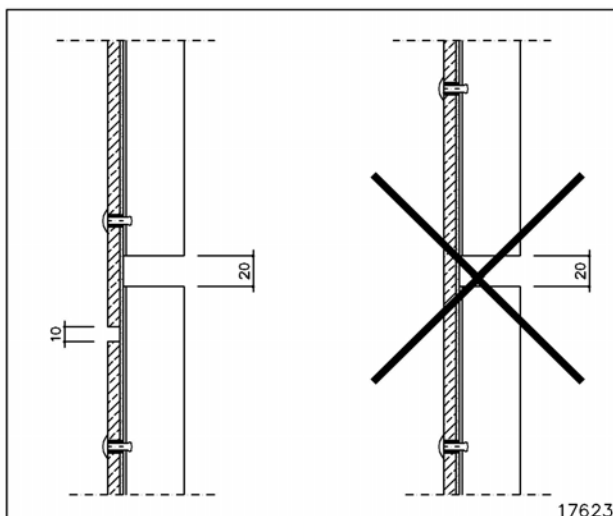

6 Fixing method

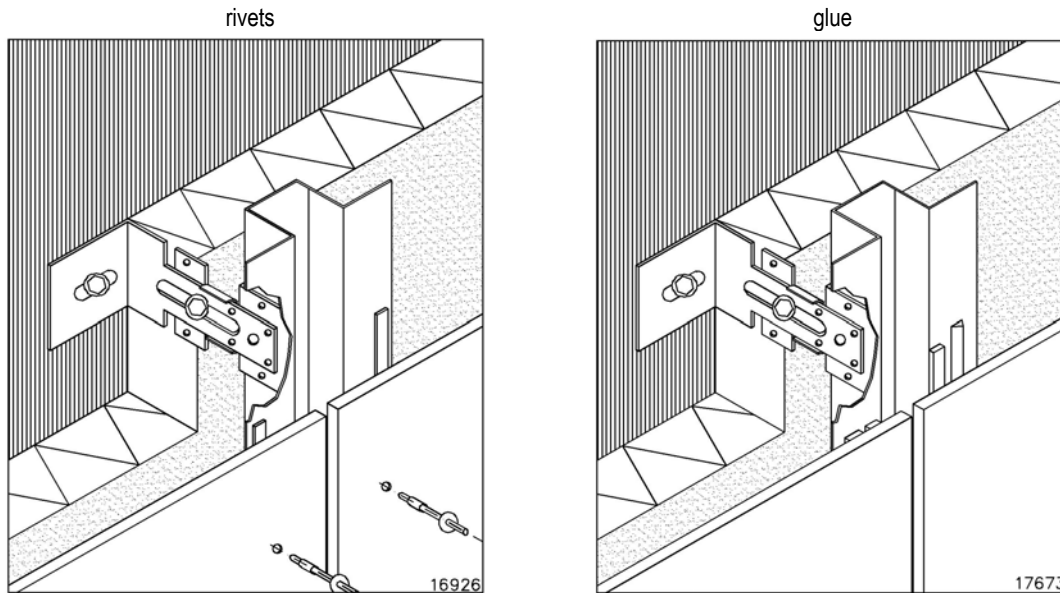

6.1 Maximum distance between stainless steel profiles

The horizontal centre to centre distance between the supporting profiles is determined by:

- the width of the panel
- the maximum centre-to-centre distance of the supporting structure (see § 3 page 1)
- the maximum distance between the fastening accessories depending on calculated wind loads (see below)
- the distances from the edge of the screws (see § 6.2)
- the joint opening

As a general rule the following maximum distances between the fixing accessories must be respected.

Occuring wind load N/m ²	Maximale centre distance of fasteners mm
≤ 800	600
≤ 1200	500
≤ 1500	400
> 1500	300

For single spans the following maximum distances between the fixing accessories must be respected.

	Maximale centre distance of fasteners mm	
	Land 0-20 m	Land 20-50 m Kust 0-20 m
Single span	500	400

Example (fixing with rivets):

width of panel = 1220 mm, maximum distance between screws = 600 mm, distance from edge rivets = 40 mm, joint opening = 10 mm

→→→centre to centre distance between supporting profiles = $(1220+10)/2 = 615$ mm

→→→ distance between the screws = $(1220-2*40)/2 = 570$ mm ≤ 600 mm

6.2 Invisible fixing through bonding¹

6.2.1. Fixing method

Bonding must always take place in accordance with the conditions of the supplier of the bonding system and under his supervision and guarantee conditions. Bonding on a metal supporting structure is a more durable system than bonding on a wooden supporting structure.

OPERAL can be glued providing the following additional limitations are respected:

- the maximum height amounts to 10 metres
- vertical wooden supporting laths
- ventilation behind the sheet must be ensured
- maximum distance between the adhesive piece amounts to 400mm

Whether panels can be glued or not depends on the chosen bonding system.

- Always consult the complete gluing advice of the manufacturer of the glue!
- An excellent quality of the glue can only be obtained by strictly following these instructions.
- Always work with certified products (KOMO, ATG or equivalent), tested on Euro Panels Overseas N.V. material.
- The above mentioned list is regularly subject to changes. Always consult the manufacturer of the glue to be informed on the latest updates.

Depending on the chosen bonding system it is possible that:

- The backside of the panel must be raised with sandpaper P80 on the spot of the adhesive bonding
- The supporting laths must undergo prior treatment with an adhesion primer. Hereby the supporting laths must suffice with regard to the requirements made for the application of the adhesion primer (e.g. maximal moisture level, prescribed wood preservation techniques).
- The façade panel must be cleaned and be given prior treatment with an adhesion primer.

A double-sided adhesive strip is applied as support for the façade panel during the hardening period of the glue, while also indicating the distance between the façade panel and the wooden supporting laths. The correct quantity of glue must be applied. The application of the façade panel requires the necessary precision.

Gluing always has to be done on multiple support structure, or in other words, gluing on a simple support structure is forbidden because of aesthetic reasons.

6.2.2. Edge distances

The following maximum edge distance must be respected.

- Maximum edge distance of the glue : 50 mm

The following schematic drawing illustrates the gluing procedure.

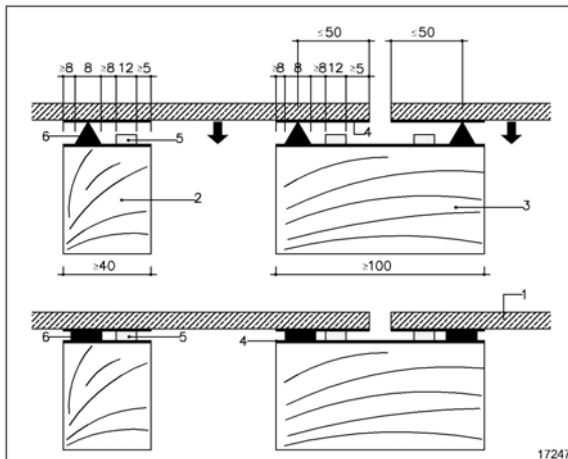

1. Façade panel
2. Supporting lath without joint
3. Supporting lath with joint
4. Adhesion primer
5. Double-sided adhesive strip
6. Glue

¹ The maximum height can be restricted by the conditions of the supplier of the glue or by prevailing legislation.

6.3 Visible fixing with rivets

6.3.1. Fixing method

The cladding panel is fixed with blind rivets with coloured heads. The blind rivets are inserted using an electric blind rivet machine.

Drilling through the stainless steel section must be done perpendicular and central with respect to the panel perforations. The predrilling of the aluminium section takes place using a special centring drill.

The blind rivets must be inserted perpendicular to the panel surface. The mouthpiece of the blind rivet machine may not damage the blind rivets.

The distance from edge of the drilled hole to the edge of the stainless steel section may not be too small.

- minimum distance from edge of drilled hole stainless steel section : 10 mm

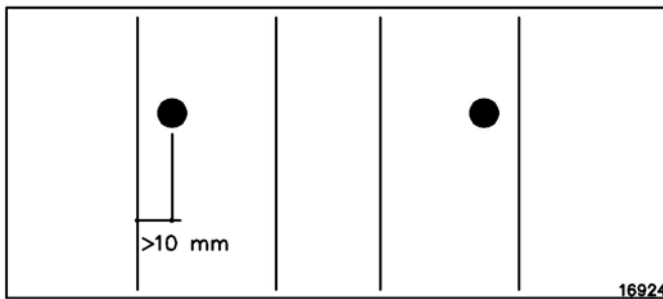

Drilling shavings must be removed before the drilled hole is blown out so that they do not become stuck between the panel and the section. For the same reason, the bottom blind rivets are only fixed after all drilling shavings have been removed by gently knocking the panel.

The cladding panels are fastened by fixed and free fastening points. Two adjacent fixed fastening points (F) are provided for each panel. All other pre-drilled holes are free fixing points to allow movements of the panel (G).

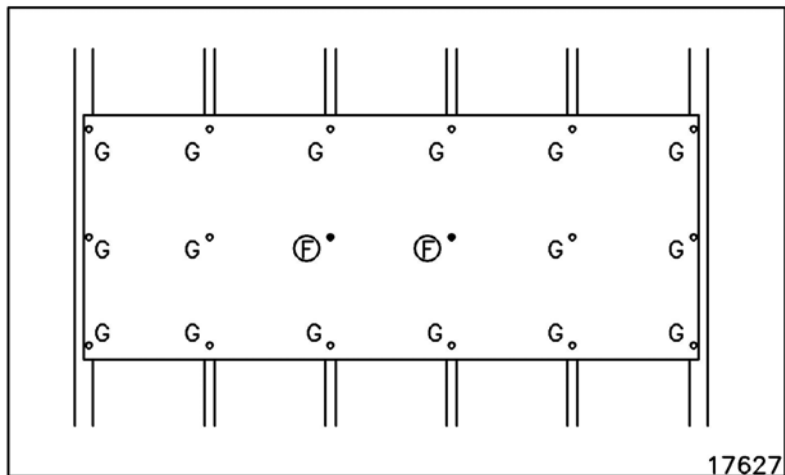
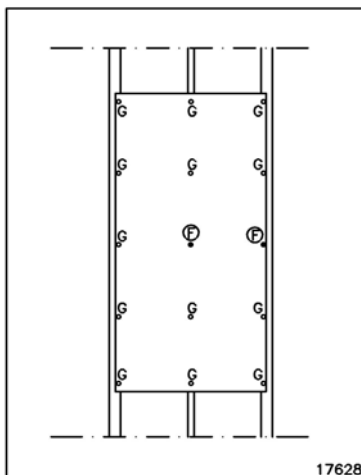

6.3.2. Edge distances

The following minimum and maximum distances from the edges of the rivets must be respected. Drilling the holes can be done using a template.

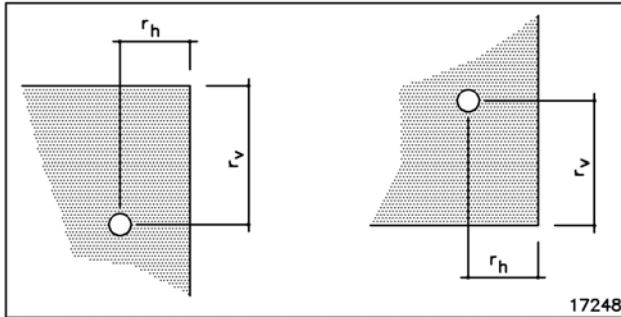

r_h	40-100
r_v	70-100

6.3.3. Type of rivets

The cladding panel is fixed to the aluminium section by means of a stainless steel (quality A2, AISI 304) ASTRO blind rivet with coloured head. The fastening system also includes ASTRO stainless steel cylinders that prevent the blind rivet coming under too much strain. As a result, the free expansion of the panel is guaranteed.

The following design of the ASTRO blind rivet and ASTRO cylinder must be respected.

For OPERAL

ASTRO cylinder OPERAL

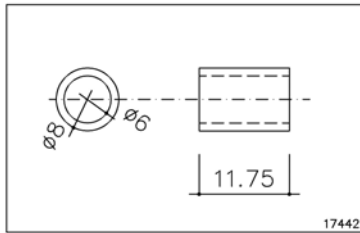

ASTRO rivet for OPERAL

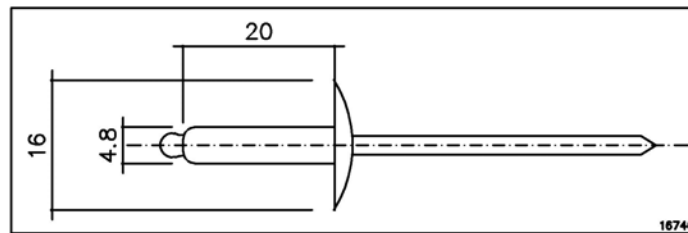

For ETER-COLOR

ASTRO rivet with fixed cylinder for ETER-COLOR

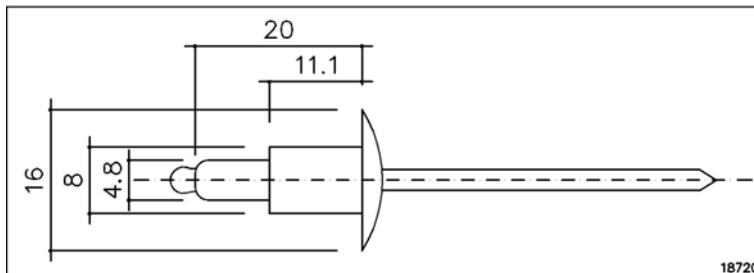

Holes for fixing points are pre-drilled in the panel.

- diameter of fixed fastening point : 8.3 mm
- diameter of free fastening point : 11 mm

After the placing of the aluminium supporting structure, strips that are self-adhesive on one side are applied continuously and vertically on the T and L aluminium sections according to diagram below. The foam strips can be pressed in to 1 mm and serve in preventing panel vibration. The foam strips are applied to the outside of the section to guide infiltrating rainwater downwards.

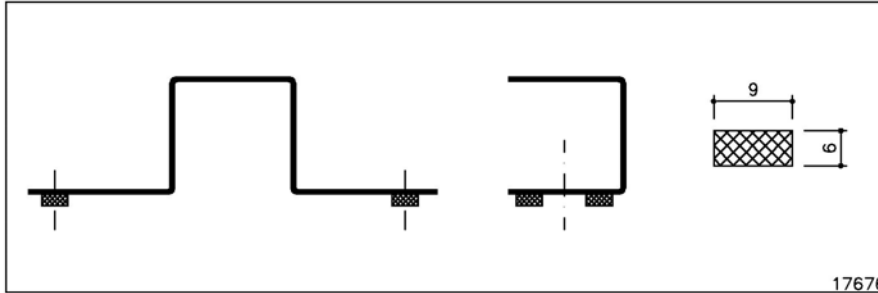

The predrilling of the aluminium section takes place using a special centring drill.

- diameter for predrilling aluminium section : 4.9 mm

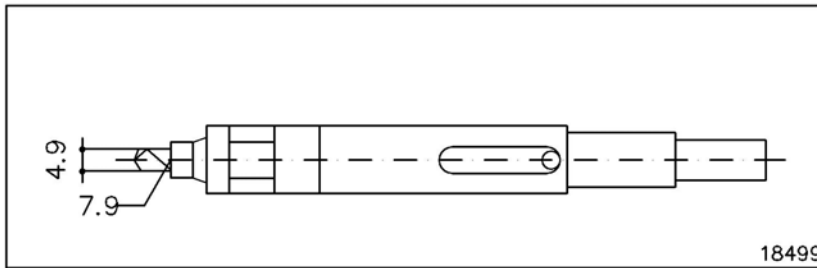

The panel is then correctly positioned and one can predrill the underlying aluminium section at the location of the fixed points (F). The façade panel is then fastened at the fixed points (F) with the ASTRO blind rivets and ASTRO cylinders by means of an electric rivet machine.

The aluminium supporting structure is then pre-drilled at the free movement points (G). The façade panel is then further fixed using the ASTRO blind rivets and ASTRO cylinders.

Fixed fastening point (F)

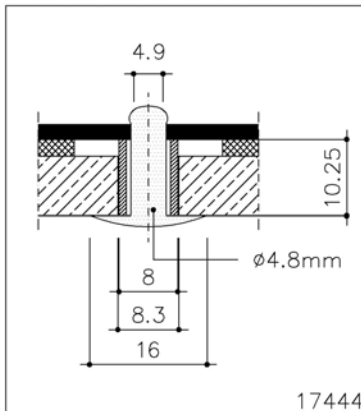

Free fastening point (G)

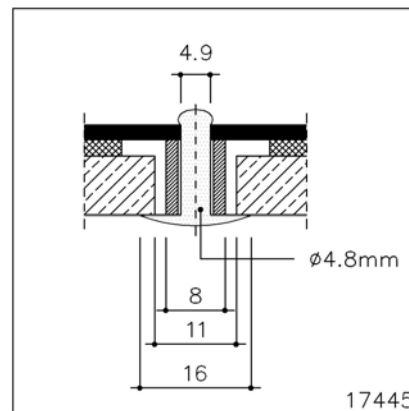

7 Joints

The façade panels are fixed with open joints to allow the free movement of the panel.

- joint width (horizontal/vertical) : 10 mm
- maximum thickness of underlying finishing profile : 0.8 mm

The vertical joints can be made black using black self-adhesive tape or a weather-resistant black coating. The vertical joints can be finished with decorative covering sections in wood or aluminium.

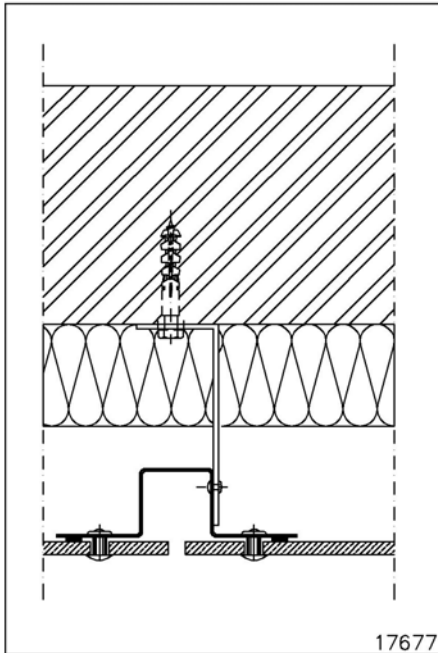

The horizontal joints can be finished with a black aluminium joint profile. This is particularly useful when the underlying insulation must be protected against the infiltration of rain. The part of the aluminium profile behind the panel may not be too thick to avoid tension. If this is the case, the wings of the profile must be wide enough for the fixing of the panel through the joint profile. The horizontal joint section is the same width as the panel so the vertical joint remains open. One can also make use of decorative horizontal joint sections. If necessary, the horizontal joints can be left open.

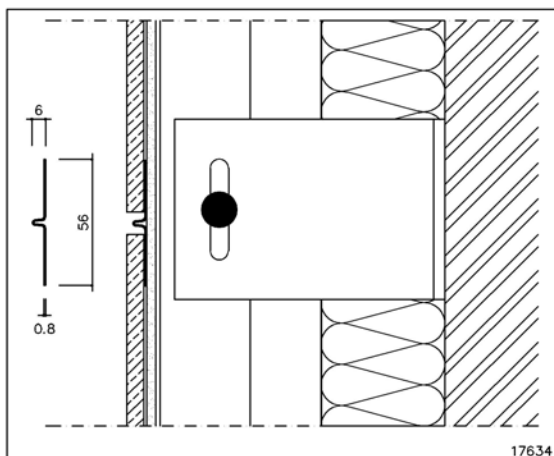

8 Accessories

The following accessories can be obtained from EURO PANELS OVERSEAS N.V..

Horizontal joint profile	Black coated aluminium	56 x 2500 mm
Perforated sealing profile	Blank aluminium	50 x 30 x 2500 mm
Perforated sealing profile	Blank aluminium	70 x 30 x 2500 mm
Perforated sealing profile	Blank aluminium	100 x 30 x 2500 mm
Outer corner profile	Black pvc	12 x 12 x 2500 mm
Outer corner profile	Anodised extruded aluminium	12 x 12 x 2500 mm
Outer corner profile	Black coated aluminium	15 x 15 x 2500 mm
Open outer corner profile	Black coated aluminium	17 x 17 x 2500 mm
Connection profile window	Black coated aluminium	8 x 15 x 45 x 3000 mm
Single sided adhesive foam strip	PVC	6 x 9 mm x 15 rm
Rivet Eter-Color	Coated stainless steel	4.8 x 20 K16 mm
Rivet Operal	Coated stainless steel	4.8 x 20 K16 mm
Centralising drill 8-11 mm	-	Ø 4,9 mm

9 Other construction details

Movements in the metal sections (corner section, bottom section, etc.) must always be detached from the panels. If necessary, the aluminium sections must be pre-drilled, and are fixed according to the principle of fixed and free fastening points. Joints between the metal sections must coincide with joints between the panels.

Finishing sections in metals that can leach (such as zinc, copper, lead, etc.) are advised against because of possible soiling.

The following construction details can be found on the EURO PANELS OVERSEAS N.V. website.

OUTER CORNER: Corner finishing can be provided by means of a joint sealing strip or a finishing profile of aluminium or PVC.

INNER CORNER: A joint sealing strip or finishing profile in aluminium or PVC can also be used here.

TOP FINISHING: Sufficient ventilation openings must be provided.

BOTTOM FINISHING: The open cavity between the back of the panel and the insulation or the back construction must be sealed at the bottom by a perforated aluminium sealing profile. This profile prevents the entry of birds and vermin. The raised leg of the sealing profile is clamped between the aluminium supporting profile and the panel and is not thicker than 0,8 mm.

WINDOW FINISHING WITH RETURN: Sufficient ventilation openings must be provided at the top and bottom of the window.

WINDOW FINISHING WITHOUT RETURN: Sufficient ventilation openings must be provided at the top and bottom of the window.

EXPANSION JOINT: The expansion joints in the building must also be included in the cladding. They are obtained by placing an aluminium profile on both sides of the joint.

10 Information on external suppliers

The following manufacturers of glue dispose of specific gluing advices and warranty declarations.

Innotec	www.innotec-world.com
Tweha	www.tweha.nl

11 Health and safety aspects

During the mechanical machining of panels, dust can be released which can irritate the airways and eyes. Apart from this, the inhalation of fine (respirable size) quartz containing dust, particularly when in high concentrations or over prolonged periods of time can lead to lung disease and an increased risk of lung cancer. Depending on the working conditions, adequate machinery with dust extraction and/or ventilation should be foreseen. For more ample information, please check the Safety Data Sheet according to 91/155/EEC.

12 More information

Information about the various cladding panels can be found in the EURO PANELS OVERSEAS N.V. product information sheets. They can be found on the website or can be obtained on demand by phone. Information about external suppliers can also be downloaded from the website.

These application instructions replace any previous editions. EURO PANELS OVERSEAS N.V. reserves the right to amend these instructions without prior notice. Readers should always satisfy themselves that they are referring to the most recent version of this document. No part of this text can be changed without permission of EURO PANELS OVERSEAS N.V..

EURO PANELS OVERSEAS NV,

p.o. Central Services
Kuiermansstraat 1
B-1880 Kapelle-op-den-Bos
Belgium

Tel 0032 (0)15 71 73 80

Fax 0032 (0)15 71 73 89

info@europanels.be

www.europanels.be



Registered office address: Bormstraat 24, B-2830 Willebroek - BELGIUM
RPR 0 466 056 888, Mechelen – VAT BE 0 466 056 888 – Bank account nr. 482-9098051-96