

Ventilated façade

1 General

These application instructions are specifically intended for the fastening of large-size EURO PANELS OVERSEAS N.V. facade panels as outside wall cladding on a ventilated and insulated wooden structure fixed to a back construction. A number of basic principles are given that must be adhered to. For variations or additional advice one can always contact EURO PANELS OVERSEAS N.V..

2 Cladding material

The following EURO PANELS OVERSEAS N.V. products are treated in this document:

• ETER-COLOR	8 mm
• TEXTURA	8 mm
• NATURA	8 mm
• NATURA PRO	8 mm
• PICTURA	8 mm

Product data and processing information can be found in the product information sheets, available from EURO PANELS OVERSEAS N.V..

For façade or ceiling applications only rectified boards may be used, non-rectified boards should not be used uncut.

REMARK: When sawing NATURA and NATURA PRO, the sawed edges must be impregnated with LUKO (a transparent impregnating agent) to minimize local colour differences due to moisture absorption.

3 Area of application

These instructions apply for buildings up to a certain height and subjected to a maximum actual wind load in a certain wind zone. The maximum intermediate distance of the supporting structure is determined in relation to the occurring wind load taking into account a safety factor. The table below only shows non-binding reference values for the wind loads. The exact values can be found in the standards NBN B 03-002-1; NEN 6702:2001 and NBN-EN 1991-1-4.

Location	Building height	Middle area façade		Edge area façade and single span	
		Max. actual wind load	Max. center-to-center distance supporting laths	Max. actual wind load	Max. center-to-center distance supporting laths
Wind zone	m	N/m ²	mm	N/m ²	mm
Land	0-10	650	600	1000	500
Land	10-20	800	600	1200	500
Land Coast	20-50 0-20	1000	500	1500	400

The width of the edge area amounts to at least 1 m from the corner of the building and must be further determined on the basis of prevailing national standards and conditions. If variations of the aforementioned load limits occur (e.g. due to certain location or form factors, etc.), the design must be determined by building services engineers. The fixing of OPERAL to a building height higher than 20 m is not advised.

When the façade panels are exposed to weather conditions (rain, sun) they may only be assembled on a vertical or leaned over supporting structure. For ceiling applications reference is made to the relevant application guidelines.

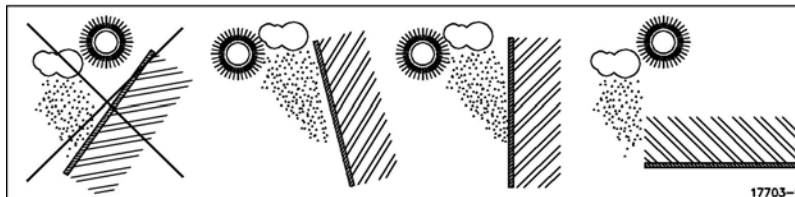

4 Patterns with large-size façade panels

The following patterns are possible. For aesthetic reasons, use rectified panels only.

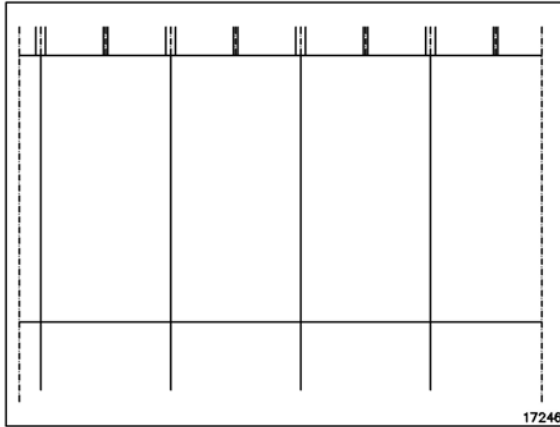

Straight pattern with vertical panels

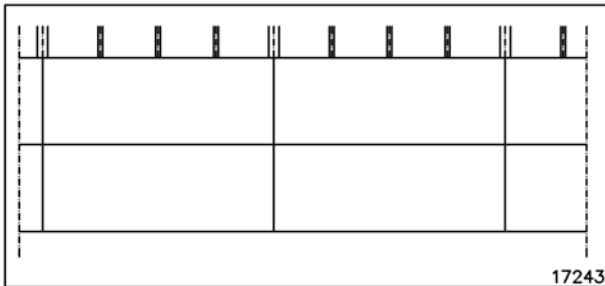

Straight pattern with horizontal panels

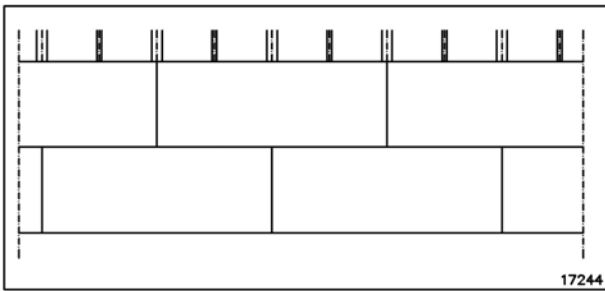

Semi pattern with horizontal panels

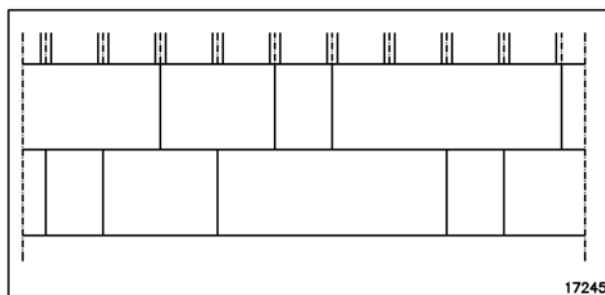

Free pattern with horizontal panels

NOTE: semi pattern and free pattern are only advised for dark colours.

5 Supporting structure

The EURO PANELS OVERSEAS N.V. large-size facade panels are fixed on vertical wooden supporting laths. The vertical supporting laths are fixed at a certain distance (depending on the required insulation thickness and air cavity) on the back construction by means of adjustable brackets or horizontal wooden cross laths.

The supporting structure must be able to resist the wind forces exerted on the building and the load of its own weight.

- maximum buckle under the influence of strain : $\leq \text{span}/300$
- safety factor calculation of strength : 3

The quality of the wood must suffice with regard to that described in the prevailing standards for this area of application. The wood must also be protected against being affected by fungi, etc. in accordance with the prevailing standard.

- minimum characteristic bending strength of wood : 18 N/mm²
- minimum average modulus of elasticity : 9000 N/mm²

The fastening of EURO PANELS OVERSEAS N.V. facade panels must always take place with a ventilated cavity. The necessary openings are provided on the bottom side, top side and in the details to allow sufficient ventilation.

Badly ventilated façade panels could result in physical problems for the construction and differences in colours under influence of humidity for panels with a semi-transparent coating.

- ventilation openings above/below : $\geq 10 \text{ mm/m}$ or $100 \text{ cm}^2/\text{m}$

Building height	0-10 m	10-20 m	20-50 m
Minimum cavity width	20 mm	25 mm	30 mm

Mineral wool with a water-repellent black protective coating is recommended for insulation. The insulation is fixed with synthetic insulation fastenings. The insulation is fastened according to the instructions of the producer of the insulation, e.g. with five insulation fasteners per square meter.

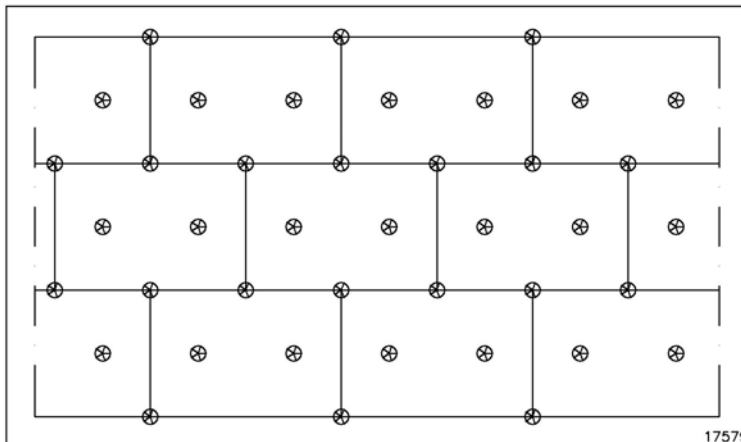

If the wooden supporting laths are fixed with brackets, the insulation is fastened after the fitting of the brackets and before the fitting of the wooden supporting laths. A slit is cut in the insulation at the bracket.

It is preferable to isolate the bracket from the supporting wall by using a piece of hard insulation material (THERMOSTOP).

If the wooden supporting laths are fixed with wooden cross laths, the insulation is placed in between the cross laths before the fitting of the wooden supporting laths.

VARIANT 1: INSULATION BETWEEN ADJUSTABLE BRACKETS

With uneven back constructions the vertical wooden supporting laths can be fixed using adjustable brackets. Corner brackets are available on request for the corners.

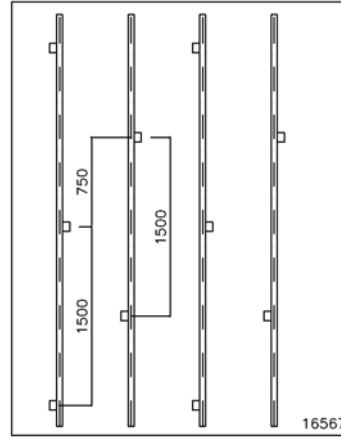
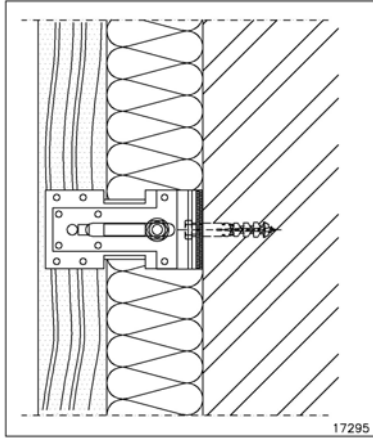

Adjustable bracket

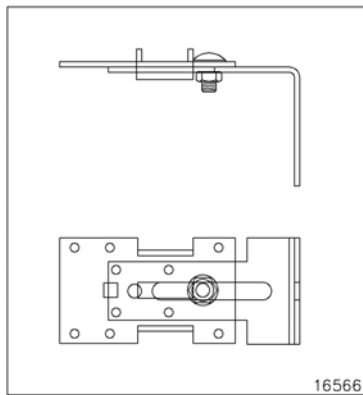

Thermostop

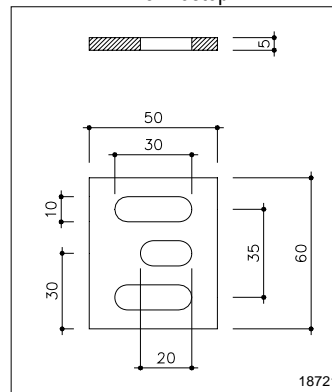

The supporting lath is sufficiently thick to enable the good fix of the brackets, and the adjustable bracket has the following properties.

- minimum thickness supporting lath : 50 mm
- bracket material : at least Sendzimir galvanised steel
- continuous remote control : 60 - 120 mm (back construction - rear lath)

The fixing of the adjustable brackets to the back construction is individually determined for each project depending on the nature and the state of the wall to be claded.

In general a minimum pull-out value per fixing point of 3 kN (300kg) is recommended. This must however be verified for each project. For concrete and solid brick a stainless steel wood screw (min. 7 mm diameter) with a hexagonal head and associated nylon plug is used. The screws with hexagonal head are, however, not tightened too firmly so thread in the nylon plug is not damaged.

For other surfaces (hollow brick, cellular concrete, system walls, etc.) suitable fastening means must be used to be able to accommodate the tractive force occurring as a result of the wind load and the shearing forces as a result of the own weight. If necessary a pull-test must be conducted on site. The supporting laths are to be fixed to the adjustable bracket by means of four stainless steel wood screws per bracket. The screws must penetrate at least 25 mm in the supporting lath.

To obtain a stable supporting structure, the adjustable brackets are alternately placed to the left and the right of the supporting lath. The brackets of two supporting laths located next to each other are also fitted staggered.

VARIANT 2: INSULATION BETWEEN HORIZONTAL CROSS LATHS

For wooden frame constructions or sufficiently smooth back constructions, the insulation is placed between horizontal wooden cross laths to which the vertical supporting laths are fixed.

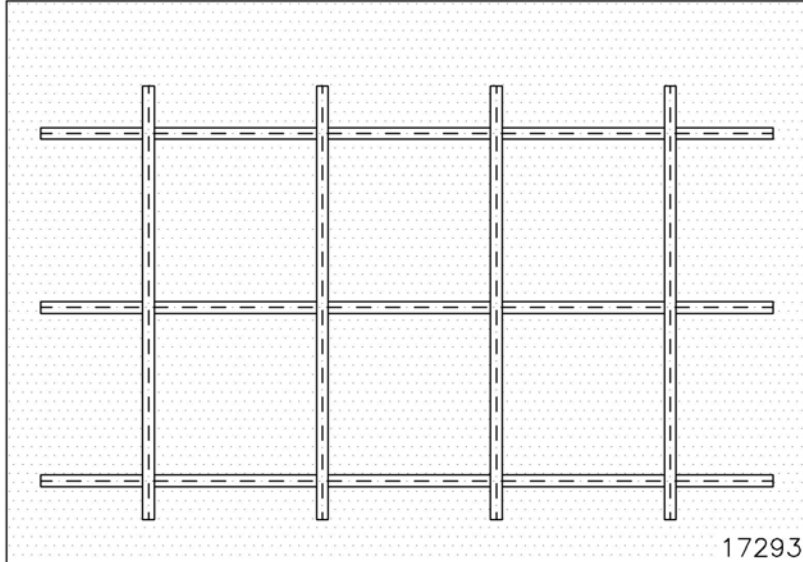

The fixing of the horizontal cross laths to the back construction is individually determined for each project depending on the nature and the state of the wall to be claded.

In general a minimum pull-out value per fixing point of 3 kN (300kg) is recommended. This must however be verified for each project. For concrete and solid brick a stainless steel wood screw (min. 7 mm diameter) with a countersunk head and nylon plug is usually used. The screws are, however, not tightened too firmly so thread in the nylon plug is not damaged.

For other surfaces (hollow brick, cellular concrete, system walls, etc.) suitable fastening means must be used to be able to accommodate the tractive force occurring as a result of the wind load and the shearing forces as a result of the own weight. If necessary a pull-test must be conducted on site.

The vertical supporting laths are fixed to the horizontal wooden cross laths by two stainless steel wood screws per crossing point.

- minimum width of horizontal cross lath : 60 mm
- minimum thickness of horizontal cross lath : 30 mm

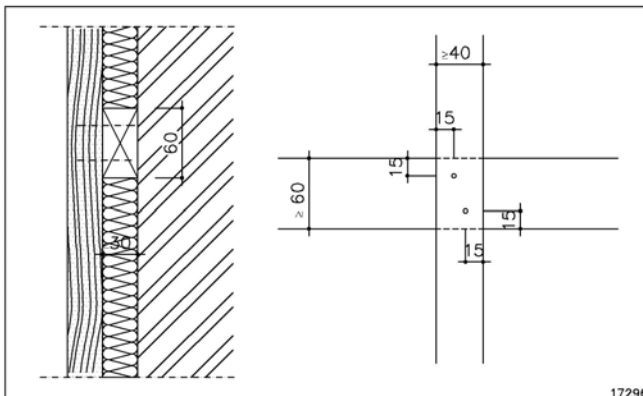

VERTICAL WOODEN SUPPORTING LATHS

The vertical wooden supporting laths are planed on one side and aligned in the same plane when placing to obtain sufficient evenness. The wood must also be sufficiently stable so that alignment is retained. A small expansion joint is left between the wooden supporting laths.

- maximum unevenness : $\leq L/1000$
- joint between supporting laths : $\geq 5\text{mm}$

The wooden supporting laths are placed vertically so that penetrating or condensation water can run down from the back of the panel (and does not stagnate on the wooden laths).

The wooden supporting laths must be sufficiently wide for sufficient water sealing and the correct fitting of the fastening accessories. At vertical joints it is recommended to use slightly wider wooden supporting laths than the minimum width to be able to accommodate tolerances in alignment (and therefore avoid "air screws").

Fastening	screws
Minimal width supporting lath without joint	$\geq 40\text{ mm}$
Minimal width supporting lath with joint	$\geq 90\text{ mm}$
Advised width supporting lath with joint	110 mm

The vertical supporting laths must be sufficiently thick to resist occurring forces and to enable the correct application of the fastening accessories.

Fixing with adjustable brackets

- Minimum thickness of supporting laths : 50 mm
- Maximum distance between brackets : $\leq 1500\text{ mm}$

Fixing on horizontal cross laths

Distance between horizontal cross laths	Minimum thickness of the vertical supporting laths
600 mm	$\geq 30\text{ mm}$
800 mm	$\geq 35\text{ mm}$
1000 mm	$\geq 40\text{ mm}$
1200 mm	$\geq 45\text{ mm}$
1500 mm	$\geq 50\text{ mm}$

APPLICATION PROCEDURE

The following procedure can be used for the fitting of large-size facade panels on a wooden supporting structure by means of adjustable brackets.

1. Check the straightness of the wooden laths
2. Use the facade cladding design plan to mark off the centre to centre distances between the supporting laths on the facade by means of a plumb-rule or a laser
3. Fit the adjustable brackets
4. Fit the supporting laths on the brackets
5. Align the supporting laths horizontally and vertically in a section by the gradual arrangement of the brackets (maximum unevenness is less than $L/1000$)
6. Fit the EURO PANELS OVERSEAS N.V. large-size facade panels. One starts at the top of and fits the panels using a metal lath with straight edge that are clamped on the supporting laths. Damaging the panel is avoided by assembling from top to bottom. Calibrated plates can be used to assemble the panels with the correct joint width. To obtain an attractive result it is best to minimise the tolerance of the vertical joints compared to the tolerance of the horizontal joints.
7. The calibrated plates have to be removed carefully, so that the sheet edges are not damaged.

6 Fixing method

6.1 Visible fixing with screws

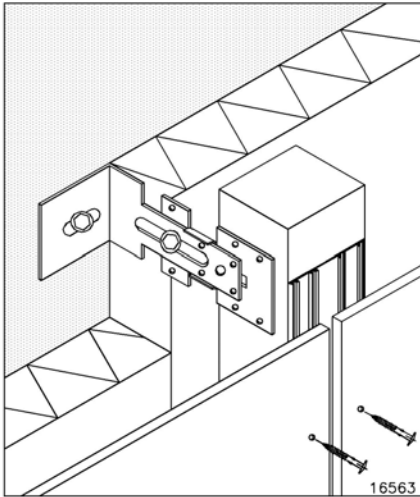

The cladding panel is fixed by means of a stainless steel (quality A2, AISI 304) panel screw with coloured T20 TORX head to the wooden supporting laths.

- minimum screw depth in supporting lath : 25 mm
- minimum distance from screw edge in supporting lath : 15 mm

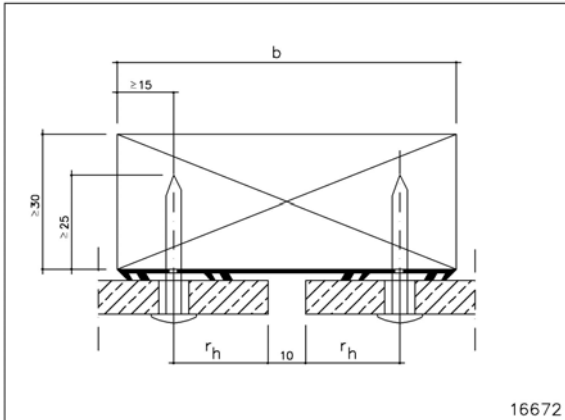

b	≥90
r _h	25

The screws are inserted using an electric drill with a high quality bit suitable for the type of screw head. The screws must be inserted perpendicular to the panel surface, and may not be tightened to too firmly so that the free expansion of the panel is impeded. This is achieved by limiting the moment setting of the drill.

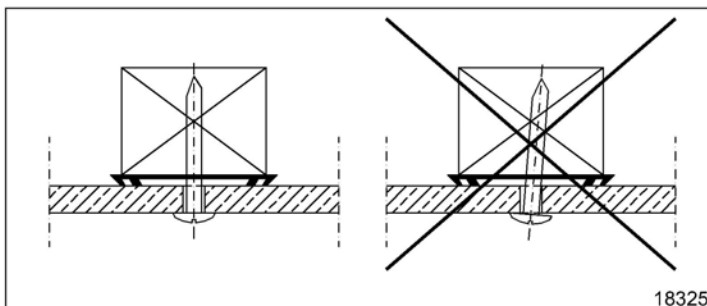

6.2 Edge distances

The following minimum and maximum distances from the edges of the fastening accessories must be respected. Drilling the holes can be done using a template.

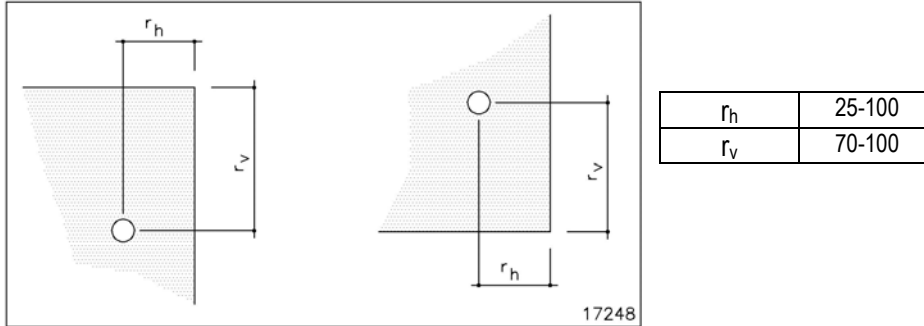

6.3 Maximum distance between wooden supporting laths

The wooden supporting laths are placed vertically so that penetrating or condensation water can run down from the back of the panel (and does not stagnate on the wooden laths). The design plan of the facade cladding shows the supporting laths.

The horizontal centre to centre distance between the supporting laths is determined by:

- the width of the panel
- the maximum centre-to-centre distance of the supporting structure (see § 3 page 1)
- the maximum distance between the fastening accessories depending on calculated wind loads (see below)
- the distances from the edge of the screws (see § 6.2)
- the joint opening

As a general rule the following maximum distances between the fixing accessories must be respected.

Occuring wind load N/m ²	Maximale centre distance of fasteners mm
≤ 800	600
≤ 1200	500
≤ 1500	400
> 1500	300

For single spans the following maximum distances between the fixing accessories must be respected.

	Maximale centre distance of fasteners mm	
	Land 0-20 m	Land 20-50 m Coast 0-20 m
Single span	500	400

Example (fixing with screws):

width of panel = 1220 mm, maximum distance between screws = 600 mm, distance from edge screws = 25 mm, joint opening = 10 mm

→→→ centre to centre distance between supporting laths = $(1220+10)/2 = 615$ mm

→→→ distance between the screws = $(1220-2*25)/2 = 585$ mm ≤ 600 mm

When de façade panels are exposed to weather conditions (rain, sun) they may only be assembled vertically. For ceiling applications reference is made to the relevant application guidelines.

6.4 Type of screws

a. ETER-COLOR

The following design of the screw must be respected.

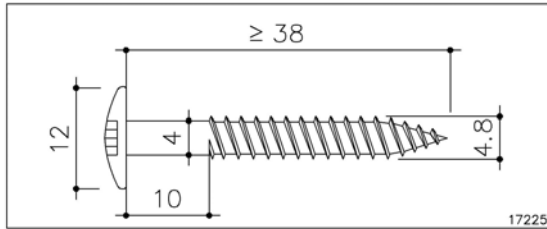

Holes for fixing points are pre-drilled in the panel. For each panel two fixed fastening points (F) located side by side are provided. All other pre-drilled holes are free fixing points to allow movements of the panel (G).

- diameter of fixed fastening point : 5 mm
- diameter of free fastening point : 8 mm

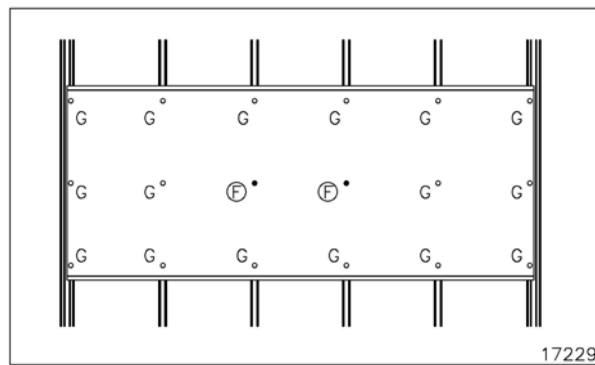
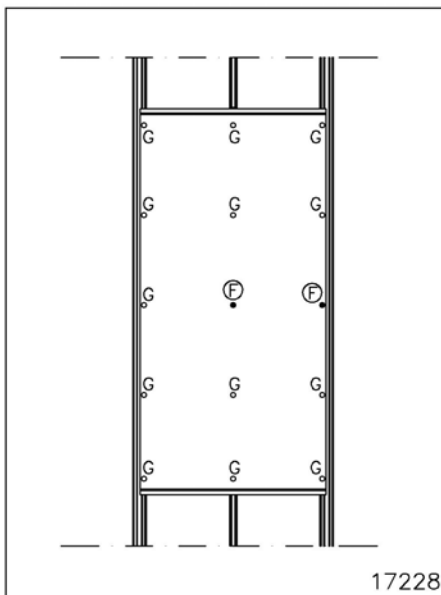

The screws must be applied in the centre of the pre-drilled holes.

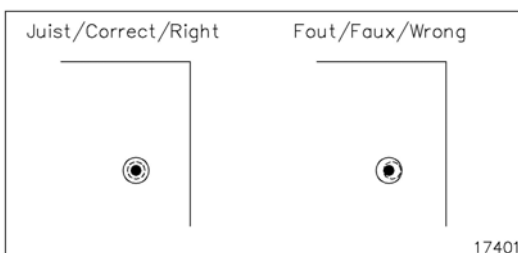

b. TEXTURA, NATURA

The following fixing instructions must be respected.

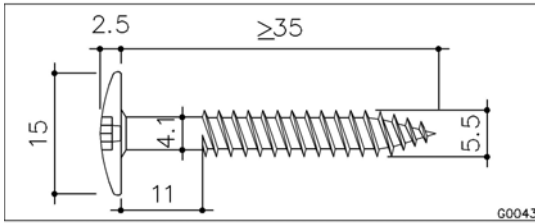

Holes for fixing points are pre-drilled in the sheet. Only pre-drilling with special fibre cement drills in hard metal.

- diameter fixing point: 6 mm

c. PICTURA, NATURA PRO

The following fixing instructions must be respected.

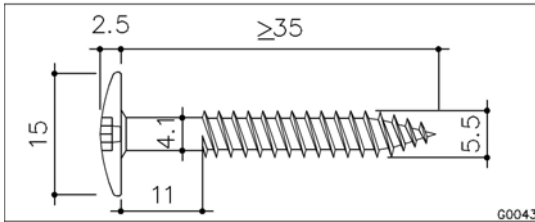

Holes for fixing points are pre-drilled in the sheet. Only pre-drilling with special fibre cement drills in hard metal.

- diameter fixing point: 7 mm

A special sleeve is placed in the drill holes to protect the surface of the PICTURA and NATURA PRO panel.

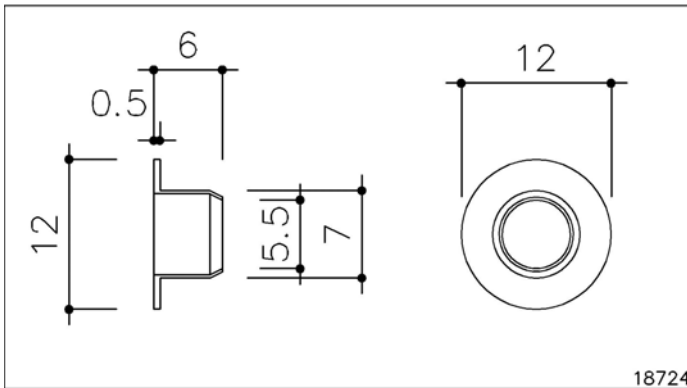

The protective sleeve is patented under nr. EP 2 096 231

7 Joints

The facade panels are fixed with open joints to allow the free movement of the panel.

- joint width (horizontal/vertical) : 10 mm
- maximum thickness of underlying finishing profile : 0.8 mm

At the vertical joints, the supporting laths are covered with a UV-resistant EPDM joint profile provided with ridges. The joint sealing strip must always cover the wooden supporting lath over the complete width. The screw must be fixed between the ribs of the joint profile in such a way that penetrated rainwater can run off between the ribs. An EPDM joint sealing strip is also applied on the centre support to obtain even spacing. One can also make use of a flat joint sealing strip in EPDM or black aluminium. The vertical joints can be finished with decorative covering sections in wood or aluminium.

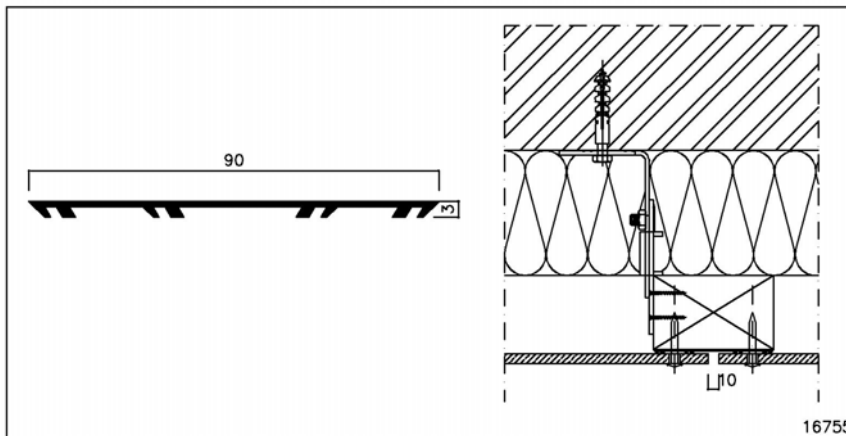

The horizontal joints can be finished with a black aluminium joint profile. This is particularly useful when the underlying insulation must be protected against the infiltration of rain. The part of the aluminium profile behind the panel may not be too thick to avoid tension. If this is the case, the wings of the profile must be wide enough for the fixing of the panel through the joint profile. The horizontal joint section is the same width as the panel so the vertical joint remains open. One can also make use of decorative horizontal joint sections. If necessary, the horizontal joints can be left open.

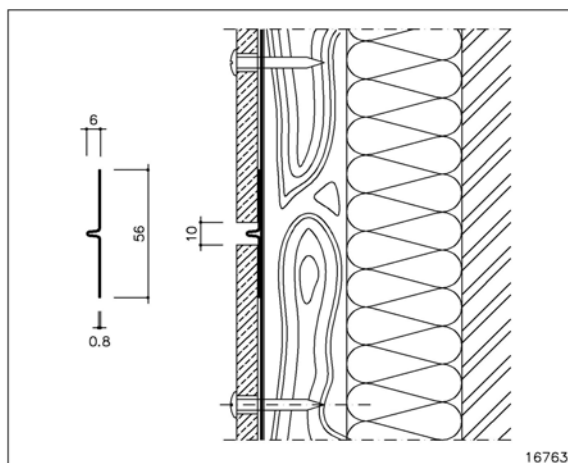

8 Accessories¹

The following accessories can be obtained from EURO PANELS OVERSEAS N.V..

Horizontal joint profile	Black coated aluminium	56 x 2500 mm
Perforated sealing profile	Blank aluminium	50 x 30 x 2500 mm
Perforated sealing profile	Blank aluminium	70 x 30 x 2500 mm
Perforated sealing profile	Blank aluminium	100 x 30 x 2500 mm
Outer corner profile	Black pvc	12 x 12 x 2500 mm
Outer corner profile	Anodised extruded aluminium	12 x 12 x 2500 mm
Outer corner profile	Black coated aluminium	15 x 15 x 2500 mm
Open outer corner profile	Black coated aluminium	17 x 17 x 2500 mm
Connection profile window	Black coated aluminium	8 x 15 x 45 x 3000 mm
Single sided adhesive foam strip	PVC	6 x 9 mm x 15 m
Joint profile with ridges for vertical joint	EPDM	90 x 1 mm
Joint profile with ridges for intermediate support	EPDM	45 x 1 mm
Flat joint profile	EPDM	100 x 0,75 mm
Screw for Eter-Color	Coated stainless steel	4,8 x 38 K 12 mm
Screw for Textura	Coated stainless steel	5,5 x 35 K15 mm
Screw for Natura	Coated stainless steel	5,5 x 35 K15 mm
Screw for Pictura	Coated stainless steel	5,5 x 35 K15 mm
Screw for Natura Pro	Coated stainless steel	5,5 x 35 K15 mm
Sleeve for Pictura/Natura Pro	Stainless steel	Ø 7 – 12 mm

9 Other construction details

Movements in the metal sections (corner section, bottom section, etc.) must always be detached from the panels. If necessary the aluminium sections must be pre-drilled, and are fixed according to the principle of fixed and free fastening points. Joints between the metal sections must coincide with joints between the panels.

Finishing sections in metals that can leach (such as zinc, copper, lead, etc.) are advised against because of possible soiling.

The following construction details can be found on the EURO PANELS OVERSEAS N.V. website.

OUTER CORNER: Corner finishing can be provided by means of a joint sealing strip or a finishing profile of aluminium or PVC.

INNER CORNER: A joint sealing strip or finishing profile in aluminium or PVC can also be used here.

TOP FINISHING: Sufficient ventilation openings must be provided.

BOTTOM FINISHING: The open cavity between the back of the panel and the insulation or the back construction must be sealed at the bottom by a perforated aluminium sealing profile. This profile prevents the entry of birds and vermin. The raised leg of the sealing profile is clamped between the wooden supporting lath and the panel and is not thicker than 0,8 mm.

WINDOW FINISHING WITH RETURN: Sufficient ventilation openings must be provided at the top and bottom of the window.

WINDOW FINISHING WITHOUT RETURN: Sufficient ventilation openings must be provided at the top and bottom of the window.

EXPANSION JOINT: The expansion joints in the building must also be included in the cladding. They are obtained by placing an aluminium profile on both sides of the joint.

CURVED APPLICATION: Façade panels in a curved construction are fixed with screws. The screws are not tightened too much so the sheets are evenly bent. The minimum bend radius is 12 m. The maximum distance between the vertical wooden supporting laths is 400 mm.

¹ Use Euro Panels Overseas N.V. accessories; not using standard Euro Panels Overseas N.V. accessories may lead to cancellation of the Euro Panels Overseas N.V. guarantee.

10 Health and safety aspects

During the mechanical machining of panels, dust can be released which can irritate the airways and eyes. Apart from this, the inhalation of fine (respirable size) quartz containing dust, particularly when in high concentrations or over prolonged periods of time can lead to lung disease and an increased risk of lung cancer. Depending on the working conditions, adequate machinery with dust extraction and/or ventilation should be foreseen. For more ample information, please check the Safety Data Sheet according to 91/155/EEC.

11 More information

Information about the various cladding panels can be found in the EURO PANELS OVERSEAS N.V. product information sheets. They can be found on the website or can be obtained on demand by phone. Information about external suppliers can also be downloaded from the website.

These application instructions replace any previous editions. EURO PANELS OVERSEAS N.V. reserves the right to amend these instructions without prior notice. Readers should always satisfy themselves that they are referring to the most recent version of this document. No part of this text can be changed without permission of EURO PANELS OVERSEAS N.V..

EURO PANELS OVERSEAS NV,

p.o. Central Services
Kuiermansstraat 1
B-1880 Kapelle-op-den-Bos
Belgium

Tel 0032 (0)15 71 73 80

Fax 0032 (0)15 71 73 89

info@europanels.be

www.europanels.be



Registered office address: Bormstraat 24, B-2830 Willebroek - BELGIUM
RPR 0 466 056 888, Mechelen – VAT BE 0 466 056 888 – Bank account nr. 482-9098051-96